



CRYSTAL  
INSTRUMENTS

# DYNAMIC TEST & MEASUREMENT SOLUTIONS

[WWW.CRYSTALINSTRUMENTS.COM](http://WWW.CRYSTALINSTRUMENTS.COM)



## Table of Contents

|  |    |
|--|----|
| <b>Technology and Innovation Drives Our Success</b>                  | 3  |
| <b>Timeline of Achievements</b>                                      | 5  |
| <b>Industries We Serve</b>   | 6  |
| <b>Vibration Control Systems Hardware Platforms</b>                  | 9  |
| Spider-81  | 9  |
| Spider-81B Economical Vibration Controller                           | 9  |
| Spider-80X   | 10 |
| Spider-80Xi  | 10 |
| High Channel Count Solution Using Spider Front-Ends                  | 12 |
| Vibration Control Systems Unique Features                            | 13 |
| <b>Vibration Control Systems Software Solutions</b>                  | 16 |
| Random Vibration Control   | 20 |
| Multi-Resolution Control   | 20 |
| Kurtosis Control & Drive Clipping                                    | 20 |
| Non-linear Control   | 20 |
| Random on Random Control   | 21 |
| Sine on Random Control   | 21 |
| Multi-Sine Control   | 21 |
| Swept Sine Control   | 22 |
| Step Sine Control  | 22 |
| Sine Oscillator  | 22 |
| Resonance Search and Tracked Dwell (RSTD) Control                    | 23 |
| Total Harmonic Distortion (THD) Measurement for Sine                 | 23 |
| Classical Shock Control  | 23 |
| Transient Time History Control (TTH)                                 | 24 |
| Shock Response Spectrum (SRS) Synthesis & Control                    | 24 |
| Time Waveform Replication  | 25 |
| Waveform Editing for TTH and TWR                                     | 25 |
| Non-acceleration Control   | 25 |
| Real-time Sine Reduction   | 26 |
| Data Transfer Tool   | 26 |
| Sensor Calibration   | 26 |
| Versatile Report Functions   | 27 |
| Front-End Calibration Tool (FECT)                                    | 27 |
| Multi-Shaker Control from One Application                            | 28 |
| Multi-Input and Multi-Output (MIMO) Control                          | 29 |
| <b>CoCo-80X Handheld System</b>                                      | 30 |
| Configurable Signal Analysis for Dynamic Signal Analyzers            | 32 |
| Vibration Data Collector   | 33 |
| CoCo-80X Specifications  | 34 |
| CoCo-80X Hardware Diagram  | 35 |
| CoCo-90 Specifications   | 36 |
| <b>Spider-20 Handheld Wireless Dynamic Signal Analyzer</b>           | 37 |
| Octave Analysis & Sound Level Meter                                  | 39 |
| Automated Production Testing Solutions                               | 41 |
| Rotational Dynamic Acquisition & Analysis                            | 44 |
| <b>Spider-80SG General Data Acquisition &amp; Strain Measurement</b> | 47 |
| Continuous Data Recording & Post Analysis                            | 49 |
| <b>EDM Modal</b>   | 52 |
| EDM Modal Geometry   | 54 |
| Operational Deflection Shape   | 54 |
| Hammer Impact Testing  | 55 |
| SIMO FRF Testing   | 56 |
| MIMO FRF Testing   | 56 |
| Standard Modal Analysis  | 57 |
| Advanced Modal Analysis  | 57 |
| <b>EDM Post Analyzer Software</b>                                    | 58 |
| EDM Post Analyzer Ordering Information                               | 60 |
| <b>Wireless Remote Condition Monitoring</b>                          | 61 |
| <b>Premier Technology Support Agreement</b>                          | 63 |

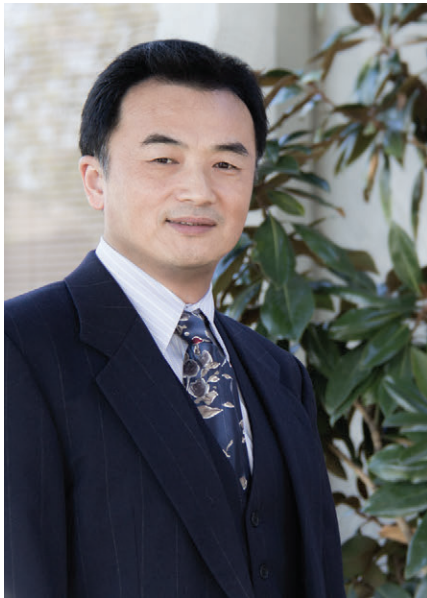

*"We believe in innovation. Innovation leads to higher quality, better solutions, and superior products. Our team's commitment to leading innovation in our industry is a great source of pride for Crystal Instruments." - James Zhuge Ph.D., President and CEO of Crystal Instruments*

## Technology and Innovation Drives Our Success

---

In 1993, only two years after I came to the USA, I read about a new technology that was just introduced into the consumer industry. Microsoft began to support the sound card with their early version of Windows. A small start-up company, m-Wave (I still remember its name), used an ADC chip which claimed to have a digital (instead of analog) anti-aliasing filter. When I looked at the existing dynamic measurement instruments, I found that the size of their digital processors was getting smaller and smaller. But the analog circuitry (and its controls) remained bulky, dominating an instrument's packaging. I also noted that high-performance analog anti-aliasing filters occupied a disproportionate amount of an instrument's printed circuit board area. These complex circuits also required careful final adjustment and tuning. The analog filter size represented a real barrier to miniaturizing a modern digital device. I thought that if we could adopt the same technology that m-Wave used in its sound card in our testing instruments, we could probably build a very small dynamic signal analyzer.

With the support of my wife, I quit my job and partnered with an ingenious hardware engineer, Gang Fang. We successfully integrated the analog-to-digital-converter (ADC) with this digital anti-aliasing filter into a type 2 PCMCIA card. It was only 5 mm thick but could do everything a HP5420 signal analyzer could. In 1996, Crystal Instruments was officially formed and we introduced the "smallest dynamic signal analyzer in the world". That product was widely used by many companies and was adopted by the US Navy. Years later, an independent company did a survey that concluded: "Crystal Instruments was the first company to adopt the sigma-delta A/D converter in this industry." Nowadays, 100% of dynamic measurement systems use sigma-delta ADCs.

In 1996, I co-founded another company, Dactron Inc. Lansmont, a well established Monterey-based manufacturer of test equipment, became its major shareholder. I identified an opportunity to build the next generation of vibration controllers. At that time, there were no controllers using Microsoft Windows programming technology or floating point signal processors in the market. Additionally, the now ubiquitous USB bus was unknown to controller users. Providing complete new hardware and software solutions for the user interface, DSP processing and external connectivity, Dactron's vibration controllers grew to take more than 50% of the world market (measured by unit sales). Dactron was then acquired by Bruel & Kjaer/LDS.

When I speak with vibration people, it sometimes seems like they come from two worlds, speaking the same words but often inferring quite a different meaning. For example, the guy who is doing rotor balancing refers to spectrum amplitude in peak units, while the user doing general dynamic signal analysis may use six different ways to describe the spectral amplitude, including power spectral density (EU2/Hz). In 2004, I thought it would be a great idea if we could make a single handheld device to meet the requirements of both the machine vibration diagnosis and dynamic signal analysis worlds. Rather than repeat the "let's educate the user" blunder, we chose to make two completely different user interfaces in the same instrument.





The CoCo-80 was a great success owing to this concept. With two different working modes, one device performs simple route data collection or advanced real-time processing. It speaks to its user in familiar words which he understands in both cases.

While we were designing the portable vibration analyzer, we became aware of a high-resolution measurement technology developed by Cisco that acquired and analyzed radio-frequency data using multiple A/D converters. In the same era, Bruel & Kjaer introduced its Dyn-X® front-end that claimed very high dynamic range in the measurement. Following this direction, Crystal Instruments developed a unique new algorithm to cross-calibrate multiple ADCs viewing the same signal through different input gains and to “stitch” their time-histories into a single glitch-free high resolution measurement. This technology completely eliminated the need for user operated gain settings in an instrument. This solved a very frustrating problem encountered when using a handheld instrument or a high channel count system. The user no longer had to optimize the input range for each channel. In a Crystal Instruments product, real-time processing does this for you automatically, providing 150 dBFS of input dynamic range.



In 2005, we saw an interesting development in the telecommunications field. Methods and standards evolved that allowed multiple network devices to be time-synchronized very accurately using nothing but the Ethernet bus itself. I was really fascinated with this idea because time synchronization is a big issue when building a distributed high channel-count dynamic signal measurement system. I met with John Eidson who invented this technology when he was employed by Agilent. John was awarded high honors by Agilent for this invention. Coincidentally, we both go to the same gym in Palo Alto, CA. We talked from time to time while John was weight lifting. I decided to adopt this technology in our next high channel count measurement system. The concepts for the Spider platform were nearly formed by then. After years of hard work by our engineering team, Crystal Instruments became one of a few first companies to incorporate IEEE 1588 PTP technology in a networked measurement platform. Measurement devices can now be time-synchronized within tens of nanoseconds while separated by hundreds of meters without using a dedicated hardware clock cable.

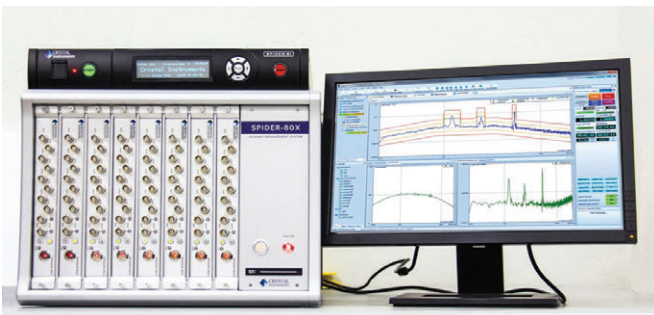

We provide innovative solutions in a very traditional market place. Our customers delve into the mysteries of acoustics, they solve vibration problems and they keep process machines running smoothly by tracking and diagnosing their signature variables. These are old problems, traditional problems. The joy of our industry is being able to bring exciting new solutions to these problems. We love to craft sharper tools for better measurement!

- James Zhuge, President and Chief Executive Officer





**2007: CoCo-80**  
Dynamic Signal Analyzer  
Vibration Data Collector



**2011: Spider-81**  
Fourth-Generation Vibration Controller



**2013: Spider-80X**  
Scalable Vibration Controller



**2015: Spider-20**  
Handheld Dynamic  
Signal Analyzer



**2016: CoCo-80X**  
Touchscreen Dynamic Signal Analyzer  
Vibration Data Collector

## Timeline of Achievements

- **1996:** Crystal Instruments released the world's smallest dynamic signal analyzer in a type-II PCMCIA form factor. It was the first vibration analyzer in the world using sigma-delta A/D converters.
- **2007:** Crystal Instruments introduced the CoCo-80, the first handheld data recorder, real-time dynamic signal analyzer, and vibration data collector that matched the performance of high end lab quality instrumentation.
- **November 2007:** The US patent office granted Crystal Instruments an important patent, #7302354. This innovation provided an advanced technique that can greatly increase measurement dynamic range and accuracy. All Crystal Instruments products use this patented technology today.
- **2009:** Crystal Instruments introduced the Spider-80, a highly scalable network-based dynamic measurement system that can measure up to 512 dynamic input channels with full data recording capability.
- **2011:** Crystal Instruments introduced the 4th generation of vibration controllers, the Spider-81.
- **2012:** Crystal Instruments received ISO 9001:2008 certification, reaffirming our dedication to high quality products.
- **2012:** Crystal Instruments released the Spider-HUB, an industrial ethernet switch with networked accuracy up to 50 ns.
- **2013:** Spider-80X is released, based on the Spider-80 design. Features two additional tachometer channels and the ability to stream data directly to a network attached storage device (Spider-NAS).
- **2014:** Spider-80SG strain gage measurement system is introduced. It includes support for quarter-bridge, half-bridge, and full-bridge installations.
- **2015:** Spider-20, the first wireless dynamic signal analyzer and data recorder is released. It is battery-powered and palm-sized.
- **2016:** CoCo-80X, the LCD touchscreen dynamic signal analyzer, is released following the success of the original CoCo-80.
- **2016:** Spider-80Xi, a compact and lightweight high channel count system is released
- **2017:** Introduced EDM Modal, a suite of tools for modal test and analysis



## Industries We Serve

---

### Machine Condition Monitoring

Smooth running process machinery buoys and maintains the world's economy. Products ranging from gasoline and chemicals to paper and steel are produced by continuous manufacturing processes. Nuclear, coal-fired, natural gas fueled, hydroelectric, wind powered or tidal-driven, power generation plants must produce continuously. Unexpected stoppages are the anathema of all these industries and vibration monitoring is a proven means of preventing them. Effectively monitoring the operating health and rapidly diagnosing the occasional mechanical woes of production machines is a vital survival mission in today's competitive business world. Today's monitoring technology has divided to follow two equally important strategic paths. Expensive plants and critical machines are continuously monitored by permanently installed systems. Less critical machines (and plants monitored by external contractors) are protected by routed periodic measurements made using handheld data collector/analyzers guided by advanced database and analysis software. Crystal Instruments produces innovative offerings in support of both strategies.

### Continuous Condition Monitoring

- Continuous measurement of shaft-to-case gaps
- Continuous measurement of case accelerations
- Track bearing temperatures, lubricant debris
- Share data anywhere, anytime via Internet
- Local recording to solid-state mass memory
- Automatic record-on-alarm operation

### Route-Based Periodic Condition Monitoring

- Design and manage monitoring relational database
- Measure consistent error-free data along route
- Make voice-annotated data recordings of problems
- Upload data to PC; generate alarms and reports
- Make at-machine diagnostic measurements
- Perform 1 and 2 plane rotor balancing



### Automotive

Automotive applications span a broad range of technology from design through product quality auditing. Manufacturers are under enormous competitive pressure to provide increasingly improved quality, safety, mileage, luxury, and economy. This places a heavy burden on automotive NVH Engineers to accomplish more, faster. Fast-paced development cycles in the modern car, truck, and coach industry demand the use of functionally flexible measurement equipment with friendly intuitive operation to unravel the dynamic and acoustic mysteries of the modern vehicle.

#### Data Acquisition and Analysis

- In-vehicle data recording and analysis with GPS
- Dynamometer testing and chassis tuning
- Drive-line balance and stability tests
- Component and body-in-white modal tests
- Pass-by acoustic monitoring
- NVH and whole body vibration

#### Vibration Control

- Component shake tests with road-recorded loads
- Material and component fatigue evaluations
- Component durability testing
- Transport simulation, time waveform replication
- Finite element model verification
- Multi-drive with multi-shaker test



### Aerospace

Development of space vehicles, satellites, fixed wing aircraft and helicopters is a technologically leading business calling for the most advanced analysis and control instrumentation. Design verification of hardware and mathematical models is an all important activity. The high cost of aerospace structures and the uniqueness of prototypes demand the most careful conduct of every controlled vibration investigation. Probing the edges of the unknown calls for extreme dynamic range and analysis flexibility in the measurement hardware employed.

#### Data Acquisition and Analysis

- Ground Vibration Tests (GVT)
- Wind tunnel dynamic studies
- High channel reliable data recording
- Flight stress and vibration recording
- External and internal acoustical surveys
- Engine durability testing

#### Vibration Control

- Sine, RSTD, Random, SoR
- Durability tests using recorded flight data
- Launch and separation simulation
- Payload dynamic qualification
- Proof-of-performance component stress screening
- MIL-Spec testing



### Education

Producing first-rate engineers is a daunting responsibility. More and more, experimental skill and experience with technologically advanced instrumentation is demanded by industry. Today's engineer needs to be both analytically competent and experimentally capable. Leading universities have broadened their curricula and softened the edge between electrical and mechanical studies to serve this need. Economic constraints place a premium on cost-effective instruments that can perform a variety of task by changing software. Flexible licensing that allows hardware modules to be used separately around the campus or to be brought together to form a large channel count system is now essential.

#### Data Acquisition and Analysis

- Introduction to digital signal processing
- Observing vibration and acoustic phenomena
- Characterizing analog electronic circuits
- Rotating machinery analysis
- Modal testing and analysis
- Real-time digital filters with configurable signal analysis

#### Vibration Control

- Introduction to electro-dynamic shakers
- Introduction to hydraulic shakers
- Concepts in shaker control
- Swept-sine testing
- Random testing
- Shock testing





### **Military**

The military forces of the United States design and acquire a variety of specialized hardware and systems for use on land, in the air and at sea. Military acquisitions range from miniaturized electronics packages to surface ships and aircraft. All of this material is subjected to rigid incoming inspection and testing in accordance with military specifications.

#### **Data Acquisition and Analysis**

- Ship and submarine silencing
- Helicopter and jet vibration
- Vehicle dynamic strain recording
- Flight/road test recording
- Engine/driveline analysis
- Route-based vibration data collection

#### **Vibration Control**

- Random shake testing
- Swept-sine shake testing
- Classical shock testing
- Drop-table shock testing
- Pyrotechnic shock tests and SRS
- Flight and launch simulations



### **Testing Labs**

Commercial testing laboratories provide capital facilities and in-depth testing expertise to industry. They often represent the least expensive means to qualify a product and prove its compliance to a broad range of specifications and codes. Leading test laboratories have an extensive range of shaker and shock test facilities supported by the most modern control and analysis electronics available.

#### **Data Acquisition and Analysis**

- Stress and vibration recording
- CE requirement testing
- Product vibration surveys
- Component modal studies
- Servomechanism verification
- Circuit performance tests

#### **Vibration Control**

- Product durability testing
- Random, SoR, RoR shake testing
- Swept-sine, RSTD shake testing
- Shock-on-shaker testing
- Seismic testing and earthquake simulation
- Combined thermal and stress testing

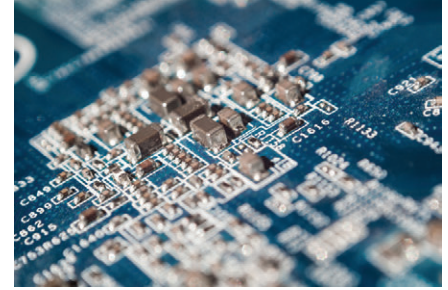

### **Electronics**

The electronics industry spans and affects every aspect of human life. It is an extremely broad industry ranging from military hardware to personal entertainment products and everything in between. Personal computers, tablets and smart cellular telephones are part of everyone's life and of many industrial systems. Chronometers, radar, sonar and GPS let us navigate our world precisely. Radios, television and the internet keep us informed and communicating. All of these things have analog components to be understood and packaging concepts to be qualified.

#### **Data Acquisition and Analysis**

- Analog circuit bench testing
- Analog network analysis and tuning
- Characterizing component background noise
- Measuring gain, phase and linearity
- Magnetic field frequency response
- Verifying system poles and zeros
- Automated production test

#### **Vibration Control**

- Highly accelerated stress screening (HASS)
- Highly accelerated life-testing (HALT)
- Package design verification
- Spec-qualifying a module, chassis or rack
- Environmental simulations; packaging tests
- Drop-testing shock response analysis
- Sine and dwell test for qualification

## Vibration Control Systems Hardware Platforms



*Spider-81 Premium Vibration Controller*



*Spider-81B Basic Vibration Controller*



### Spider-81

The Spider-81 is the flagship model; all other Crystal Instruments controllers have evolved from it. This 4th generation hardware is highly modular, distributed and scalable. Each Spider-81 has 8 analog input and 4 analog output channels. Analog monitoring channels serve an attached oscilloscope. Eight digital I/O pairs are provided for custom applications. The Spider-81 features a bright front panel LCD that displays system status and test information. Real-time status such as control RMS or sweeping frequency is instantly viewed on the LCD.

The Spider-81 does not just use Ethernet for data communication, it employs IEEE 1588v2 time-synchronized Ethernet connectivity. This technology allows (100 meter!) remote input modules to be connected solely by Ethernet (no dedicated “sync” cable required), yet still provides sampling and triggering synchronized within the accuracy of 50 ns. The Spider-80X front-ends and the Spider-HUB industrial Ethernet switch may be used to expand the Spider-81 controller up to 512 input channels. All input channels across the system are amplitude matched within 0.1 dB and phase matched within 1° over a 20 kHz bandwidth.

All Spider front-ends contain a 4 GB flash memory for the storage of data and test processing instructions. If longer recording is required, the Spider-NAS (Network Attached Storage) provides 250 GB of solid state disk (SSD) storage in a removable SATA cartridge. One Spider-NAS records streamed time waveforms and spectra from up to eight Spider front-ends at the speed of 102.4 kHz per channel. The rapid transfer rate allows continuous recording of all channels at a measurement front-end’s highest sample rate.

Multiple Spider-81 front-ends and the Spider-80X front-ends can integrate to construct a higher channel system. The Spider-81B front-ends is not expandable by design.

### Spider-81B Economical Vibration Controller

The Spider-81B front-end is a smaller, simplified system featuring 4 input channels and 1 output. This system provides everything needed to run Sine, Random or Shock tests measuring the control and up to 3 monitor signals. The Spider-81B has 4 pairs of DIO. This basic system actually provides a very comprehensive facility with the same control quality, safety assurance, measurement precision, expandability and human interface that distinguish all Crystal Instruments controllers. The Spider-81B is ideal for educational institutions and small R&D laboratories.



*Shown here are the Spider-80XA35, the Spider-HUB, the Spider-NAS, and 9 Spider-80X front-ends*



*The Spider-80X is designed for vibration control, machine monitoring, and data acquisition.*



*The Spider-80Xi is a compact, lightweight, high channel count data acquisition system intended for portable field use*

### Spider-80X

The Spider-80X, a compact package, is designed for application in three fields: dynamic data acquisition, vibration control, and machine monitoring. It features eight analog input channels and two channels that may be software selected as analog outputs for vibration control or tachometer inputs for the analysis of rotating machinery. A single Spider-80X front-end is a complete two-output controller with the same high quality patented dual ADC input technology as the Spider-81 series. The Spider-80X inputs provide absolute/differential and AC / DC / IEPE coupling choices; charge mode is an available option. The Spider-80X provides the same time sync Ethernet connectivity and 4 GB flash memory for data and program storage. Multiple Spider-80X front-ends may be linked together using the (eight-into-one) Spider-HUB module and storage can be increased to 250 GB by adding a Spider-NAS mass storage module.

### Spider-80Xi

The Spider-80Xi is a compact version of Spider-80X with an extremely lightweight form factor. Featuring a 64 channel chassis weighing less than 10.5 kg, the Spider-80Xi can be carried in one hand and is optimal for field environment testing where portability is essential.

Like the Spider-80X, multiple chassis combine to create a system up to 512 channels, all sampled simultaneously. A dedicated massive storage hard disk (a solid state hard-drive with a capacity of 250GB) allows the time signals of all input channels to record at up to 102.4 kHz/channel. Accurate time synchronization results in excellent phase match in the frequency domain between all channels, either on the same Spider front-end or across different front-ends. Real time FFT, octave, order tracking or vibration control functions can be enabled. The modular boards of the Spider-80Xi are installed at the factory and are not onsite swappable.

The Spider-80Xi system consisting of the 64 channel chassis is powered by AC power, at 100 to 240 VAC. The Spider-80Xi system consisting of the 32 channel chassis is powered by the DC power, at 10V to 22V. The latter is also easily operable with an external battery pack. With the Spider-Battery, (developed by Crystal Instruments) a 32 channel Spider-80Xi system operates up to 4 hours without interruption.





*The Spider-100 Temperature, Humidity, & Vibration Controller*

### Spider-100

The Spider-100 is specifically designed to perform all types of tests where the DUT is subjected to simultaneous vibration, temperature cycling, and variable humidity, including Highly Accelerated Stress Screening (HASS) and Highly Accelerated Life Testing (HALT). The Spider-100 controls temperature, humidity, and vibration harmoniously in a chamber and shaker system, which includes external heating/cooling and humidification/dehumidification systems. The communication between numerous devices is optimized by the Spider-100 in an integrated design to achieve high control accuracy. The Spider-100 provides eight input channels and two shaker drive outputs for linear shaker control. When a pneumatic hammer table is used, the controller commands the RMS vibration level via its 4-20 mA current-loop output to the table's pressure control valve. There is a total eight 4-20 mA analog out channels offered on the Spider-100. Additionally, the Spider-100 provides ten 4-20 mA analog input channels for humidity sensors and eight temperature input channels for 3-wire RTD or T-type thermocouples. Thirty relay control channels control the heaters, valves, and fans of the chamber. Thirty-two channels of programmable digital I/O are available for user-defined applications.

|                         | Spider-81   | Spider-81B                        | Spider-80X  | Spider-80Xi  |
|-------------------------|---|-----------------------------------|---|--|
| Number of Inputs        | 8 per front-end expandable to 512   | 2, 4 not-expandable               | 8 per front-end expandable to 512                                   | 8 per front-end expandable to 512  |
| Number of Outputs       | 4   | 1                                 | 2   | 2  |
| Input Mode              | Charge<br>TEDS<br>IEPE<br>Voltage   | Charge<br>TEDS<br>IEPE<br>Voltage | Charge (optional)<br>TEDS<br>IEPE<br>Voltage                        | Charge (external)<br>TEDS<br>IEPE<br>Voltage   |
| Digital I/O             | 8 in/out, isolated  | 4 in/out, isolated                | 4 in/out, isolated  | 4 in/out, isolated   |
| Front Panel LCD         | Yes   | No                                | No  | No   |
| High Speed Data Port    | Yes   | No                                | Yes   | Yes  |
| Analog Monitor Channels | Yes   | No                                | No  | No   |
| Notes                   | Flagship product for VCS line. Input protection up to 250V. Equipped with Stop/Start button | Economical solution               | Target at all VCS, Modal and DSA application. Modular at box level. | Compact version of Spider-80X. Target at all VCS, Modal and DSA application. Modular at PCB board level. |

## Spider-80Xi System (512 Channel Count)

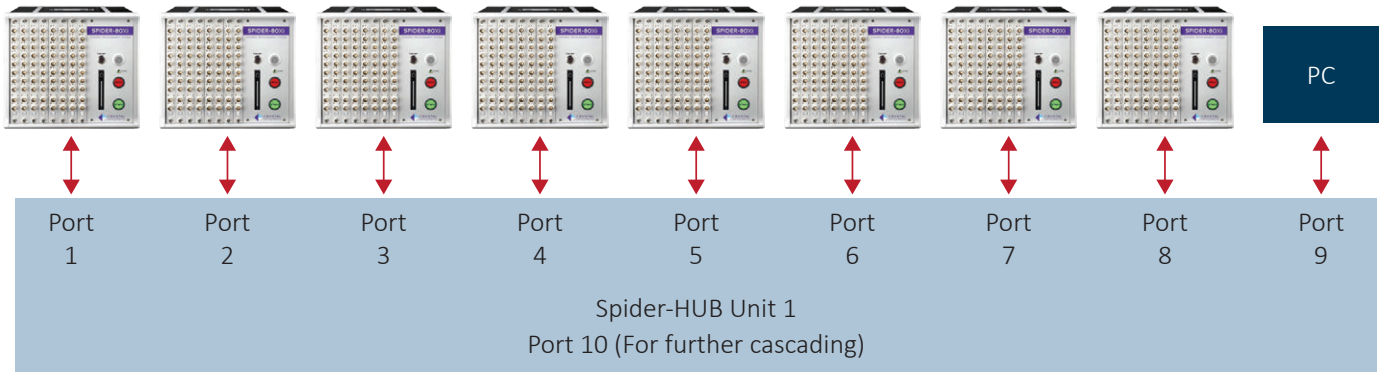

## High Channel Count Solution Using Spider Front-Ends

By using superior Ethernet and time synchronization technology developed by Crystal Instruments, the Spider system can be extended to support up to 512 input channels. When the system is running with multiple module with hundreds of input channels, all data acquired are simultaneous and accurately phase matched. The phase match accuracy can be less than 1 degree within the normal testing frequency range. By having such high phase match, the frequency response function of cross channel measurement can be used for analyzing the characteristics of UUT (unit under test) such as modal shape and damping ratio.

In a Swept Sine test that runs hundreds of input channels, the tracking filter and notching can be applied to any of input channels. In a Random control, monitoring channel, limiting, Sine-On-Random can all be applied to all input channels simultaneously. In TTH or Shock, all data capture among all channels will be acquired simultaneously. CI's Spider system is the only product in the world that fully integrates the DSA and VCS functions that can run up to 512 channels.

The data recording can be realized on Spider systems via either of two approaches: record the time-stream data into the flash memory on each of Spider front-end or, record the time-stream data into an external storage device, such as the Spider-NAS. The Spider-NAS can store simultaneous data from all (64 maximum) attached dynamic measurement channels at a sample rate as high as 102.4 kHz, or as low as a few samples per second.



Spider-HUB Industrial Ethernet Switch



Spider-NAS Storage Device

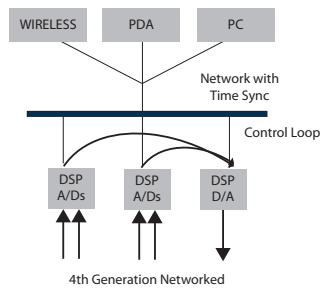
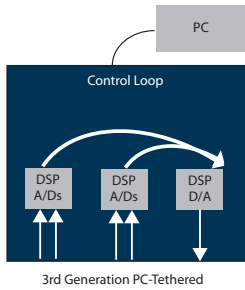
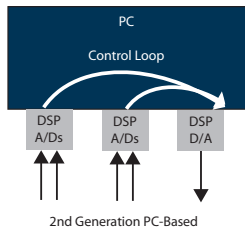
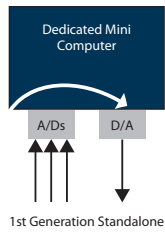

The Spider platform is based on a fourth generation DSP centralized architecture.

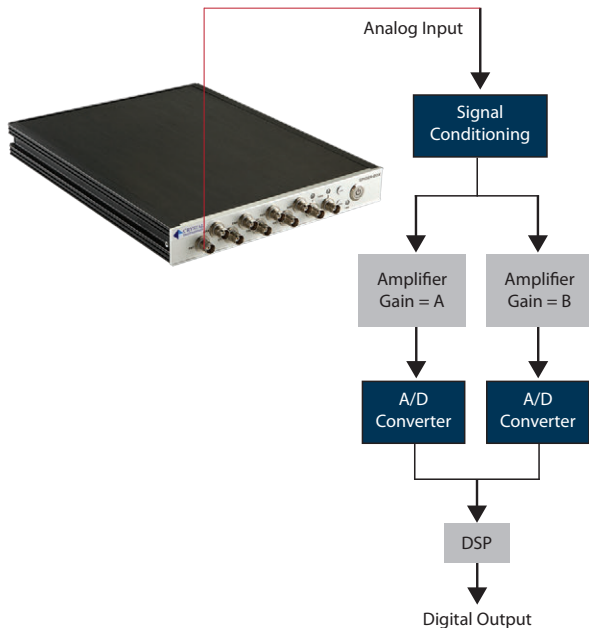

Hardware per US Patent 7,302,354 applies two ADCs to each input channel.

## Vibration Control Systems Unique Features

### Latest Hardware Design

The Spider front-ends have voltage, IEPE and charge inputs which are ideal for shock, vibration, and acoustic measurement, strain or general purpose voltage measurement. The internal flash memory stores test configuration data for controlling up to hundreds of channels simultaneously and stores real-time analysis data. Multiple output channels provide various signal output waveforms that are synchronized with the input sampling rate. Ten monitoring connections on each unit are used to read analog input and output signals. There is a built-in isolated digital I/O to interface with other hardware. Our scalable architecture allows users to employ as many as 512 input channels for the utmost spatial resolution. Sampling to 102.4 kHz provides excellent time resolution while spectra with up to 12,800 lines may be controlled. Data is stored into 4 GB of internal flash memory. Increased storage space is possible with the addition of a 250 GB external unit.

### Shaker Compatibility

Spider controllers work with any electrodynamic, servo-hydraulic, or servo-electric shaker with all ranges of force ratings, from tiny desktop to multi-ton water cooled systems. Frequency range can be from sub 1Hz to 40kHz.

### High Precision Front-End Design

The Spider analog input channels provide extremely high precision measurements. Each channel has single-ended or differential AC or DC input coupling. It can also provide IEPE (ICPT™) input mode (AC coupling with a 4 mA constant current from a 24 VDC source) for use with industry-standard accelerometers with built-in amplifiers. The ability to read TEDS (Transducer Electronic Data Sheet) identification from the attached transducer completes the channel's compliance with IEEE 1451.4.

In some models, built-in charge amplifiers are available. For pyrotechnic and other high-shock applications or tests involving very high DUT temperatures, each input channel can accept a charge-mode piezoelectric sensor input directly without using an expensive external charge amplifier.

It is unnecessary to adjust the input range of any channel; these are fixed at  $\pm 20$  volts. Each channel provides an unprecedented dynamic range of 150 dBFS, detecting voltages as small as 600 nV. This is accomplished by applying two 24-bit analog-to-digital converters to each channel and combining their outputs in accordance with our United States Patent number 7,302,354.



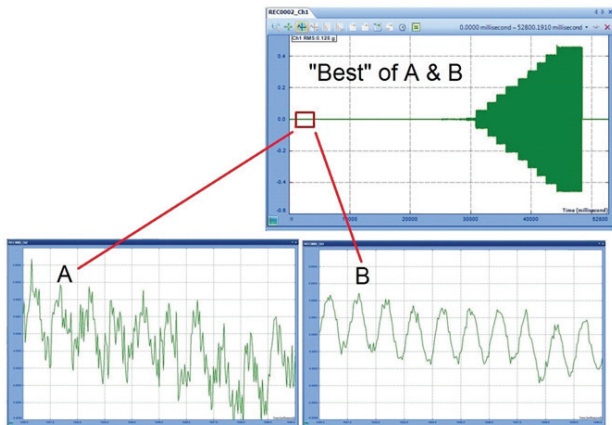

DSP knows how to pick the data from either A or B path, and “stitch” them together.

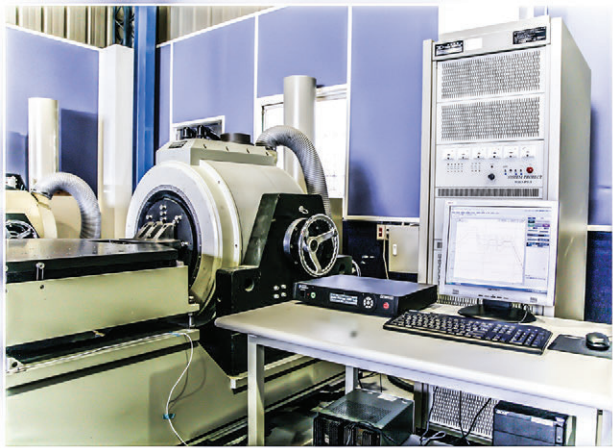

### Simple Network Connection

Ethernet connectivity allows Spiders to be located far from their host PC. This distributed structure greatly reduces noise and electrical interference in the system. A single PC can monitor and control multiple controllers over a network. Since the control processing and data recording are executed locally inside the controller, the network connection does not affect control reliability. With wireless network routers, a PC connects easily to the Spiders remotely via Wi-Fi.

### Time Synchronization between Multiple Hardware Front-ends with only Ethernet Cable

The Spider is built on IEEE 1588 Precision Time Protocol (PTP) time synchronization technology. Spider modules on the same network can be synchronized within 50 ns accuracy, which guarantees  $\pm 1^\circ$  cross-channel phase match up to 20 kHz across the complete system. With this unique technology and high-speed Ethernet data transfer, the distributed components on the network truly act as one integrated system.

### Black Box Mode

Black Box mode enables Spider operation without a PC. In this mode, a PC is used only to configure the control system before the system starts operation and to download data after the test is completed. During the test, the controller operates autonomously, according to a preset schedule or in response to a connected iPad.

### On-Board LCD Display

The Spider-81 is equipped with a bright front-panel LCD and intuitive information navigation controls. Real-time status such as control RMS or sweeping frequency is instantly viewed on the LCD.

### Designed for High Reliability

The Spider is the very first vibration control system designed for fail-safe operation even in the event of network or power loss. Advanced safety routines allow sensor failures to be detected within milliseconds. All Spider hardware pass strict environmental tests including EMI, temperature, drop shock, sine and random vibration. The system is built to withstand the rigors of the testing environment with long-lasting durability. The unique floating ground design reduces ground loop problems typically found in testing laboratories. Power backup circuitry based on a super-capacitor is installed to handle any disastrous power loss.

### Designed For High Accuracy

Using our patented parallel dual analog-to-digital converter (ADC) design, each measurement channel can detect signals as small as 600 nV and as large as 20 V. This design completely eliminates the need for the input range or gain settings found on traditional controllers. Crystal Instruments engineers have also raised many related hardware specifications to establish new industry performance standards. These include total harmonic distortion (THD), cross-channel phase match, frequency flatness, linearity, cross-talk and frequency accuracy



### **Designed for High Performance Control**

By using enhanced control algorithms and a simplified DSP architecture, the feedback loop time of Sine and Random control are greatly reduced to a 10 ms latency. Reduced control loop time improves performance for resonance search and tighter control for a structure with high-Q resonances. It also provides faster adaptive responses for better safety protection.

### **Ease of Use**

The Spider software is further improved at the user interface level. More graphical guidance, wizards, and tools are available to simplify test setup. The interface has been reformatted to be more intuitive. Event-Action Rules, Abort-Sensitivity, and numerous other new concepts are introduced in the software to simplify operation. Keyword searching through a large number of tests is easy. A smart network detection tool makes hardware installation very simple.

### **Complete Software Solutions**

The Spiders have complete software solutions available for vibration control, including Sine, RSTD, Oscillator, Random, SoR, RoR, SRoR, Classical Shock, Transient, Seismic, Shock Response Spectrum analysis and SRS Synthesis, Time Waveform Replication, HALT/HASS and multi-drive control. They cover testing to virtually all current environmental test standards. Customizable report templates allow the user to generate reports in XML, OpenOffice, PDF or MS-Word with one click. With the Application Programming Interface, Crystal Instruments' controller can be directly accessed from LabView, Matlab or other customized software. The Spiders can operate from Linux and iOS in addition to Windows.

### **Integrated Control and Dynamic Signal Analysis**

With appropriate software, the same Spider-80X hardware used for vibration control can also be used for dynamic signal analysis including machine monitoring, order tracking, modal analysis, and acoustic analysis. Multiple Spider front-ends can work together to form one integrated system. Long waveform data recording is a built-in function. An optional hardware front-end (Spider-80SG) integrates monitoring of strain gages and thermocouples.

### **Designed for High Scalability and Expandability**

With the Spider architecture, it is possible to make the hardware system ultimately scalable and expandable. A testing lab that purchases multiple front-ends of the Spider-81 or Spider-80X can freely move around their units and configure their own systems. For example, if a user purchases 8 Spider-80X front-ends, the user can use it as a 64 channel system, or separate them into two systems each with 32 inputs, or even into eight systems to control eight shakers each with 8 inputs.

# Vibration Control Systems Software Solutions

## A Wide Range of Software Functions in Vibration Control and Signal Analysis

The Crystal Instruments vibration control system (VCS) software is designed for a wide range of vibration and shock testing customers. The same software suites support from as few as two inputs up to 512 input channels with multiple drive output capability. Software solutions for vibration control include Sine, Resonance Search Track & Dwell (RSTD), Oscillator, Random, Sine-on-Ransom (SoR), Random-on-Random (RoR), Swept Random-on-Random (SRoR), Classical Shock, Transient, Seismic, Shock Response Spectrum (SRS) Synthesis, Time Waveform Replication, Highly Accelerated Life-Testing/Stress-Screening (HALT/HASS) and multi-drive control. These suites facilitate testing to virtually all current environmental test standards. Customizable report templates allow the user to generate reports in XML, OpenOffice, PDF or Microsoft Word with a single click. With the Application Programming Interface (API), Crystal Instruments' controller can be directly accessed from LabView, Matlab or other customized software. Spider front-ends run on Linux, iOS, and Windows operating systems. The VCS software also supports a wide range of dynamic data acquisition and real time processing functions including Fast Fourier Transform (FFT), Frequency Response Function (FRF), real-time filters, octave and sound level meters, order tracking, automated limit testing, transducer calibration and more.

## Common User Interface

Our Engineering Data Management (EDM) software comes with each system. EDM provides a common user interface for both VCS and Dynamic Signal Analysis (DSA) applications. A single interface with the same look and feel means that test specifications can be transferred from engineering to production without change or error and test data can be compared directly between one system and another. EDM provides a consistent user interface regardless of the application and independent of the number of hardware channels.

## Multi-Language Support

We work in a multi-lingual world. Crystal Instruments' EDM fully supports operations using English, Japanese, Simplified Chinese, Traditional Chinese or Russian (others on request) user interfaces. The selected language can be changed at any time with one mouse click.

## Versatile Report Functions

The advanced report function allows users to create a report in several formats including OpenOffice, XML, Microsoft Word, ActiveX and PDF. The report is template-based. Users can customize the logo, margins, orientation of the paper, font, and the content. Microsoft Word/Office is not required to be installed to create reports. In the Review Mode, batch report can generate reports for the signals saved in multiple runs. With ActiveX reporting, signal displays in the report can be rescaled, analyzed, and zoomed.

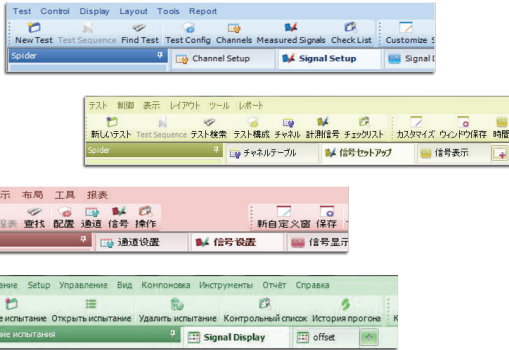

*EDM (Engineering Data Management) is available in English, Japanese, Simplified Chinese, Traditional Chinese, and Russian.*





**Step 1:**  
EDM sets the alarm limit together with a special message string, such as "Exceeding Limit".

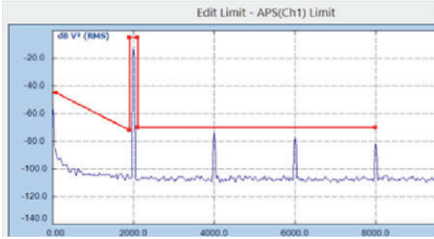

**Step 2:**  
When an alarm event happens, the customized string, "Exceeding Limit" will be sent to the EDM Cloud email service.



**Step 3:**  
User will receive an alarm email



### Easy Network Configuration

Intelligence has been built into the software so that the hardware devices on the network can be detected and accessed with little effort. A Security Access Code (SAC) is used to protect unauthorized access to the hardware on the network.

### Multi-Tab and Multi-Screen Support

To support the high channel count system that may display up to hundreds of signals, the software is designed to support multiple tabs and multiple screens. The highly flexible online display capabilities are expandable, making monitoring high-channel count systems quicker and easier. Display layouts for each tab and screens can be set up and stored for rapid access.

### Safety First

Our software and hardware utilizes many safety features to ensure reliable closed-loop vibration control – from pretest checks to abort checking, notching and controlled shutdown during a test. The check-only mode allows checking the connection of sensors and verifies the amplifier status before turning the drive output on. This pretest function is an extremely powerful tool for detecting possible set-up problems before your test is started. During closed-loop control the VCS software performs RMS and line-by-line abort checks, sigma clipping and drive limitation and continuously checks for open channels and overloads. The software carefully checks for open-loop conditions such as failure of a sensor connection and verifies proper response during the initial drive ramp-up. During every test, the shaker limits (peak acceleration, velocity, displacement), maximum drive voltage and sensor connection status are continuously monitored and will initiate an emergency shutdown in case of any deficiency.

### Multi-Tasking

With DSP centralized hardware architecture, the real-time measurement and control processes are all run on the front-end hardware; users can utilize all of the capabilities of the host computer for other tasks. This multi-tasking concept guarantees powerful and time efficient vibration testing, even with time critical tests. More importantly, it provides a unique and important safety feature: any computer or network failure will not affect the vibration control.

### Test Sequence

A Test Sequence provides the capability to automatically execute a sequence of tests. The user can Run, Pause or Stop the testing at any time and the software keeps a detailed log of the actions and results.

### Event-Action Rules

Event-Action Rules is a new way to customize the controller behavior. Many events that can occur during the course of test operation, including certain response levels being reached, limits being exceeded, and user events such as Pause or Stop. Event-Action Rules define the response of the controller to these test events. Many actions are available as custom responses, such as sending an e-mail, send a digital output signal to the climate chamber or stopping the test.

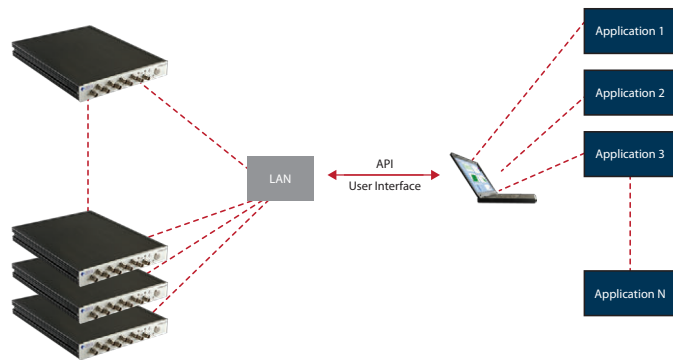
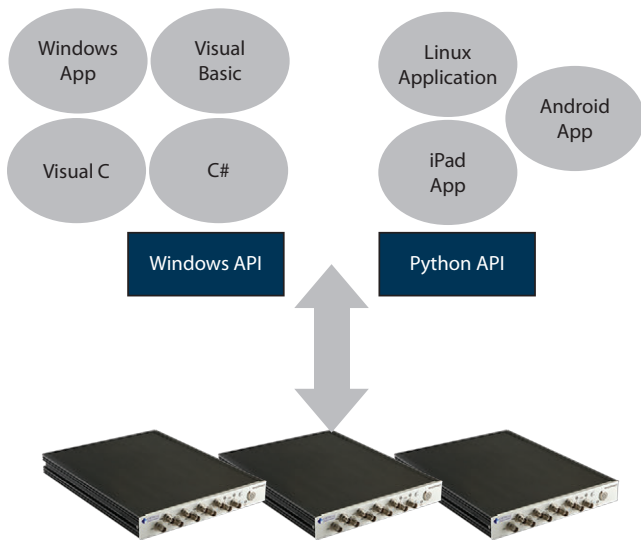

### Connectivity to Other Software, Hardware and You

Various approaches have been developed to establish the connectivity between the EDM software and other applications, such as climate chamber software or an amplifier controller. Socket messages, a common language that runs on nearly all operating systems and hardware platforms, is used to send and receive messages between EDM and other software. A digital input/output hardware interface is also provided on every Crystal Instruments product, which enables interfacing to other hardware devices. You can also automatically control the power amplifier - shut it down at a test's end and switch it on when a new vibration test is to be started. When the system is left running but unattended (e. g. for an overnight or weekend run), you still remain in control. Test status reports can be sent via email or SMS text message to your mobile phone, enabling you to decide whether to return to work or not within minutes of the test stopping.

### Continuous Time Data Recording

The Spider platform is capable of recording the data of 512 control/monitor input channels sampled at up to 102.4 kHz. The storage can be either internal flash memory or a dedicated SATA hard-disk. The reliability of the software for such real-time data transfer has been fully validated. Continuous recording happens in parallel with vibration control and neither is affected by the other.

### Database Technology

By using latest database technology, EDM can quickly search, index and organize the testing setup and data. On the company network different testing stations can share the same database.

### Application Programming Interface (API)

Crystal Instruments' Spider Application Programming Interface (API) is a collection of Windows Dynamic-Linked Libraries (DLL) or Python API providing an easy path for external applications to access and control the Spider-80X hardware.

If Windows OS is used, the user can develop their own applications in Windows App, VC, VB or C# languages. If Linux, iOS or Android is used, a Python API serves as the control interface.

The Spider API defines a set of command structures based on character strings. This implementation is widely compatible with various connection tools such as APIs, scripts, socket messages and handheld devices, facilitating future technical support.

### Location ID and Customized Signal Labeling

In EDM, signals can be clearly labeled with names conveying physical meaning, such as "Top" or "Front". All related signals will be renamed with such labeling automatically.

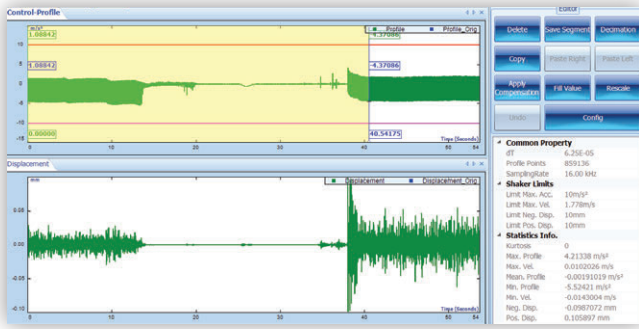

### Check List for the Initial Startup

EDM can show an overview of the critical parameters to be verified before a test is actually started.

### Instant Color and Style Change of UI

EDM provides a wide selection range of colors and styles for text, signals and backgrounds.

### Complex FRF/Transmissibility

EDM software has a very flexible setup to measure the matrix of complex motion/force FRF (or g/g transmissibility's) which are critical for modal analysis,

### Flexible Math function

EDM software provides flexible math functions to perform block arithmetic on signals using +, -, \*, / or other arithmetic operations. Math functions can be applied in both time and frequency domains.

### Non-Acceleration Measurements

Any input channel can measure any type of physical signal such as displacement, temperature or pressure.

### Remote Operation Communication using Socket Messages

Communicate with and control Spider systems remotely with Window socket messages. Socket messages also allow communication with other hardware, such as temperature chambers. Please refer to document for Socket Message for detail specs. The ability to send emails or instant messages as custom actions in response to a system or user event. Content of emails can be customized.

### Shaker Parameters

Shaker limits are calculated from the shaker parameters and the weight of the Unit Under Test (UUT). Shaker Parameters include maximum amplifier input voltage, shaker acceleration, velocity, displacement, force, drive frequency, and mass of UUT. Shaker library settings are saved to a library and used repeatedly in different tests. Shaker parameters are imported from or exported to a Microsoft Excel spreadsheet.

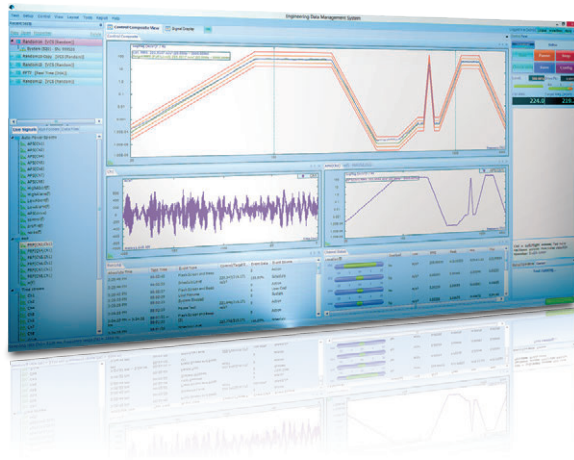
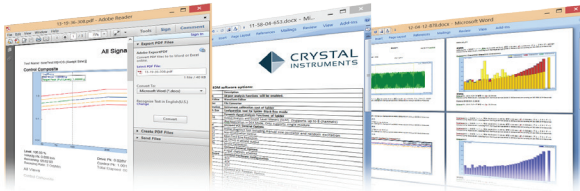

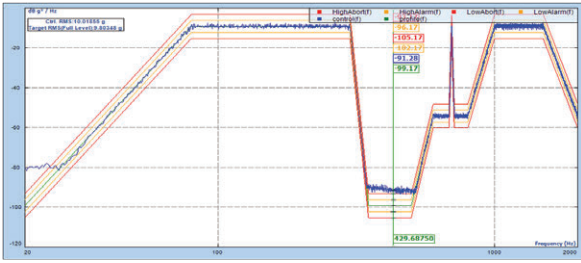

Random control dynamic range of up to 90dB

### Random Vibration Control

Random Vibration Control provides precise multi-channel control in real time. The device under test is subjected to true random noise with a precisely shaped spectrum with either Gaussian or non-Gaussian amplitude statistics. With a control dynamic range up to 90 dB, up to 512 channels can be enabled for Control, Notching, Monitoring and time data recording. The recording option records time-stream data at the full sample rate on all input channels. A unique hardware/firmware/software design featuring spectral overlapping provides a fast loop time of less than 15 ms in a typical test.



Compare control(f) with Multi-resolution control disabled and enabled. (profile range: 13~2000Hz)

### Multi-Resolution Control

The Multi-Resolution function applies the selected resolution in the high-frequency range and 8 times of the resolution in the low-frequency range. It perfectly fulfils the requirements of many Random profiles having details in the low frequency range and up to 2 kHz. Adequate loop time, spectrum refresh rate, and storage are maintained without using high resolution (large block size) that is not needed in the high frequency.

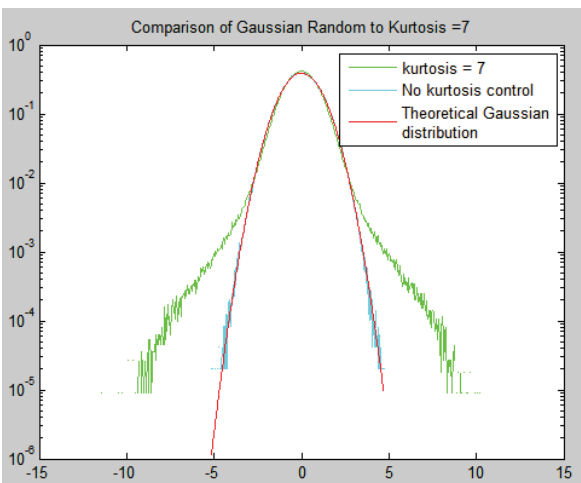

### Kurtosis Control & Drive Clipping

Kurtosis control can provide a more damaging non-Gaussian random control time history. A unique US patent 8942930 technology can generate a non-Gaussian control time history while precisely maintaining its spectrum shape. Drive clipping clamps the drive signal to maximize the power rating of the power amplifier.

### Non-linear Control

Non-linear control provides improved performance at frequencies near sharp resonances by using a unique error correction algorithm.



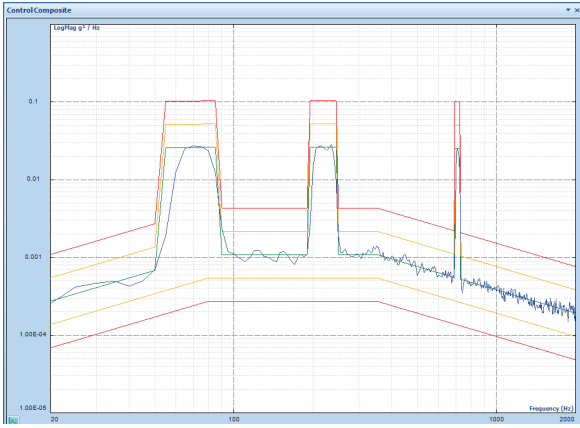

Up to 32 independent random narrow band signals

### Random on Random Control

Up to 32 independent (stationary or sweeping) random narrow-band signals may be superimposed on the broadband random signal. Each narrow-band has its own sweeping schedule and range. They can be turned on and off by a predefined schedule or manually.

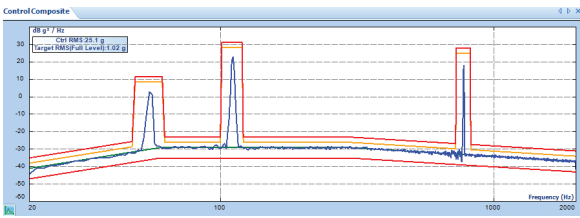

### Sine on Random Control

Up to 32 independently sweeping sine tones may be controlled in addition to the broadband random signal. Each sine tone has its own sweeping schedule and range. Tones can be turned on and off manually or by a predefined schedule.

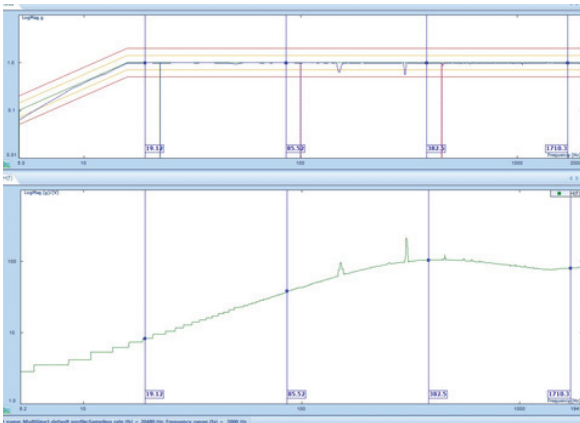

### Multi-Sine Control

Multi-Sine control enables multiple sine tones sweeping simultaneously and ensures that multiple resonant frequencies of the structure can be excited. With multiple sine tone excitation, the required time duration of sine testing can be reduced significantly. Independent tracking filters are applied to each tone separately.

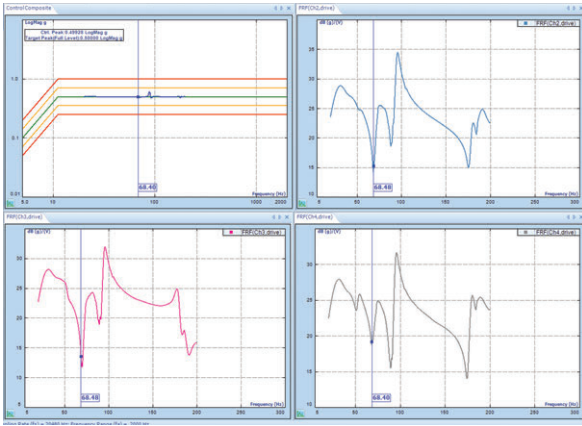

**Sine:** Provides precise multi-channel control in real time.

### Swept Sine Control

Swept Sine Vibration Control provides precise multi-channel control in real time. It provides a spectrally pure undistorted sine wave and a control dynamic range of up to 100 dB. As many as 512 channels can be enabled for Control, Notching, Monitoring and time-data recording. The recording option records a time-stream at the full sample rate on all input channels. A unique hardware design and spectral overlapping provides a fast loop time of less than 10 ms.

A random signal can be applied during pretest for checking the loop. Precise tracking filters are often applied to each channel with either fixed or proportional bandwidth. Spectral display resolution is from 256 to 4096 lines. Linear and logarithmic Sweep-speeds can be defined in Oct/Min, Hz/Sec, Dec/Min, Sweeps/Min, Sweep Time/Sweep or Cycles/Min. Non-acceleration control allows measuring and controlling on velocity or displacement sensors in lieu of acceleration. Multi-Drive control can drive more than one shaker. FRF measurement allows measuring the transmissibility between any channel-pair with high phase match. The standard frequency range is up to 4,900 Hz (up to 46 kHz optional). Notching, Alarm or Abort criteria can be set on each channel.

### Step Sine Control

Step Sine uses a sequence of short dwells within a frequency range. The steps are uniformly distributed in a log or linear frequency scale. Step Sine Entry in Run Schedule includes user defined frequency range, step resolution and dwell duration (or cycles) at each frequency.

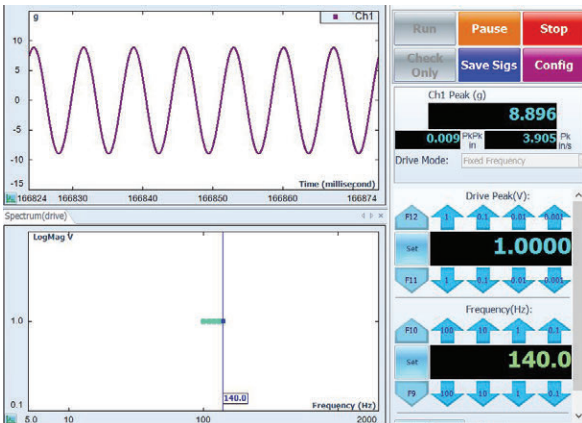

### Sine Oscillator

Sine Oscillator is a diagnosis tool with manual control of the sine output while the system displays various time signals and frequency spectra. Random excitation can be enabled as a checkup function. When the close-loop option is enabled, the Sine Oscillator is essentially a limited sine controller with more manual control functions.

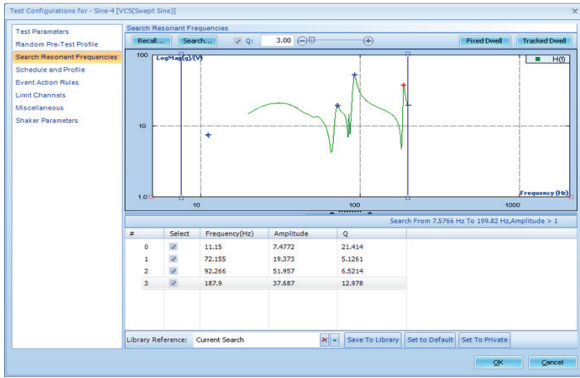

### Resonance Search and Tracked Dwell (RSTD) Control

The resonance search function determines resonant frequencies from the peaks of a transmissibility signal. Dwell type (Fixed dwell, Tracked dwell, Phase tracked dwell) may be specified manually (with a list of resonance frequencies) or automatically executed after a resonance search is done. Under real-time control, the tracked dwell entry tracks each resonant frequency as it shifts with time, temperature or damage. Phase Tracked Dwell allows tracking the resonance frequency by seeking both a peak transmissibility and a specified phase angle. Dwelling continues until time duration is reached or the resonance frequency changes outside of specified limits.

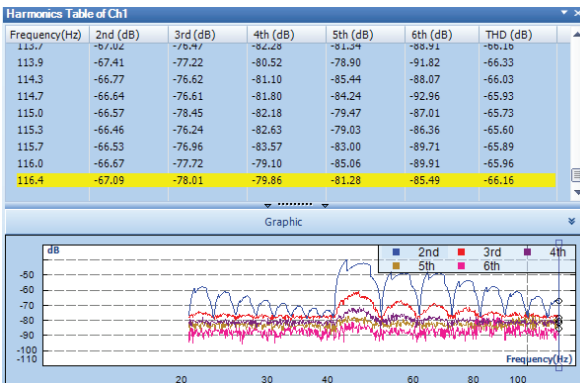

### Total Harmonic Distortion (THD) Measurement for Sine

This option adds the ability of computing Total Harmonic Distortion (THD) of the control and input signals. THD plots can be generated while drive signal either steps through multiple discrete frequencies or a swept sine tone within a predefined range.

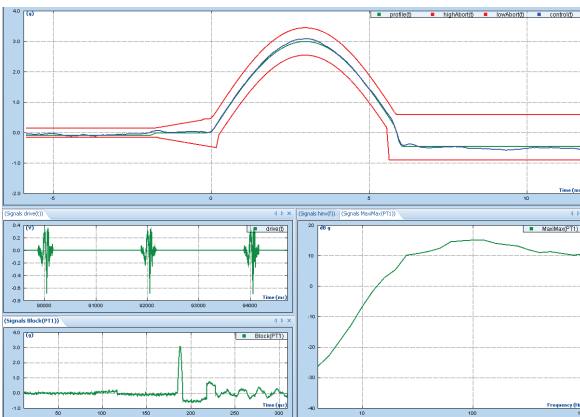

### Classical Shock Control

Classical Shock Control provides precise, real-time, multi-channel control and analysis of transient time domain motion. Classical pulse shapes include half-sine, haversine, terminal-peak sawtooth, initial-peak saw tooth, triangle, rectangle, and trapezoid. The recording option records time stream data at the full sample rate on all input channels. Shock response spectrum (SRS) analysis can be applied to any input signal; optionally control of the DUT's SRS may be executed. Applicable Test Standards include MIL-STD-810F, MIL-STD-202F, ISO 9568 and IEC 60068 (plus user-defined specifications).

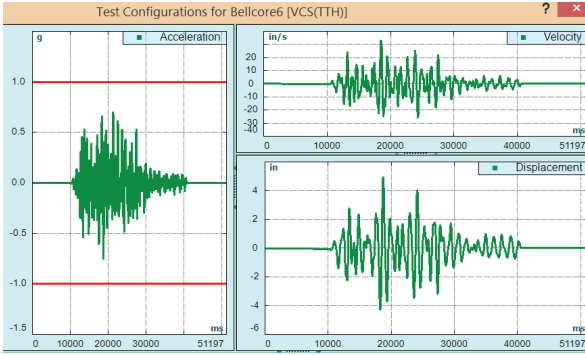

**Controls shaker motion to match a defined transient waveform**

### Transient Time History Control (TTH)

Targeting seismic simulation applications, TTH controls shaker motion to match any user defined transient waveform.

Time waveforms can be imported to EDM in various formats. Scaling, editing, digital re-sampling, high-pass, low-pass filtering and compensation will tailor the waveform so that it may be duplicated on a particular shaker. Compensation varies the waveform so that it does not exceed the maximum shaker displacement. Methods include pre-pulse, post-pulse, pre & post-pulse, DC removal and high-pass filters. Pre-stored profiles include Bellcore Z1, Z2, Z3 and Z4; Sine; Chirp; Burst Sine and others. An option is available to run profiles requiring sampling frequency lower than 120 Hz. Large block sizes up to 64,000 samples are provided.

Shock Response Spectrum analysis can be applied to any input time signals to generate SRS instantaneously. SRS Type includes maxi-max, primary, residual and composite. A low frequency option supports imported profiles with a sampling rate lower than a few Hz.

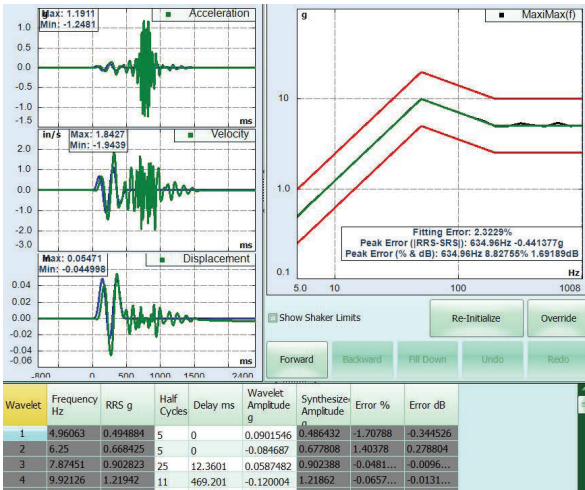

### Shock Response Spectrum (SRS) Synthesis & Control

The SRS synthesis and control package provides the means to control the measured SRS of the DUT to match a target SRS, the Required Response Spectrum (RRS). The necessary drive time-history is synthesized from damped-sine or sine-beat wavelets. Damped Sine Parameters include frequency, amplitude, critical damping factor, and delay. Waveforms may be automatically synthesized from a user-specified SRS reference profile. The Transient Control option allows control using imported transient files. High frequency waveforms, Alarm and Abort tolerances may be applied to any active channel to provide an extra degree of safety for delicate test articles.



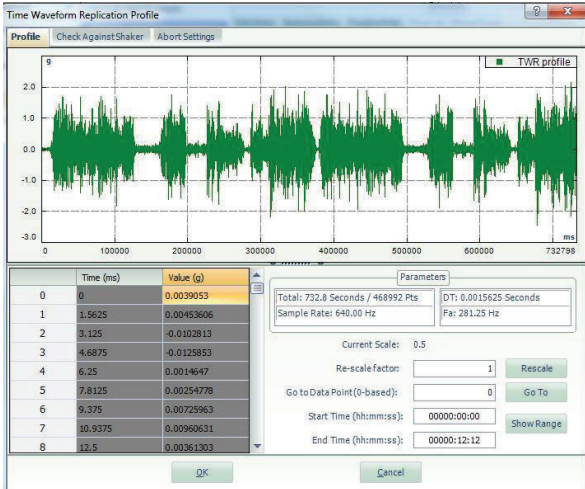

*Provides precise, real-time, multi-channel control for long waveform duplication*

### Time Waveform Replication

Time Waveform Replication (TWR) provides precise, real-time, multi-channel control for long waveform duplication. TWR includes the Waveform Editor, a flexible importing and editing tools for long waveform signals. The Recording option records time-stream data at the full sample rate on all input channels.

Multiple waveform recordings can be available in the same test to automatically run, one after the other on the test specimen. The maximum number of points is subject to the internal flash memory space available for storing profile data (currently 3.7 GB), which corresponds to approximately 1 billion data points. At a sampling rate of 200 samples/second it can replicate a waveform of about 50 days.

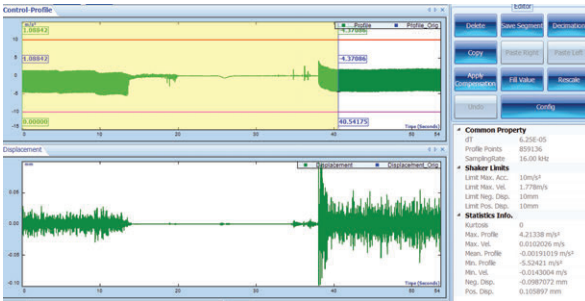

### Waveform Editing for TTH and TWR

This convenient tool provides the editing functions for any type of waveform so they can be accurately duplicated on the shaker systems. First, the user will import the data files into the Waveform Editor. The Editor can import UFF, ASCII UFF Binary, CI-ODS and other twenty types of data files. Waveforms with any sampling rates shall be digitally re-sampled, rescaled, filtered, and different compensation techniques are applied to edit the profile. It also has the options for cropping, appending and inserting parts of waveforms.



### Non-acceleration Control

With this option, a non-acceleration measurement quantity can be applied to the target profile and the control signal. This provides an option of choosing from multiple quantities including force, sound pressure, and voltage to be controlled when appropriate sensors are used. Angular acceleration can be controlled in sine and random tests using the appropriate selection. The controller is also capable of using mixed displacement, velocity and acceleration sensors to synthesize a control signal in the acceleration domain.

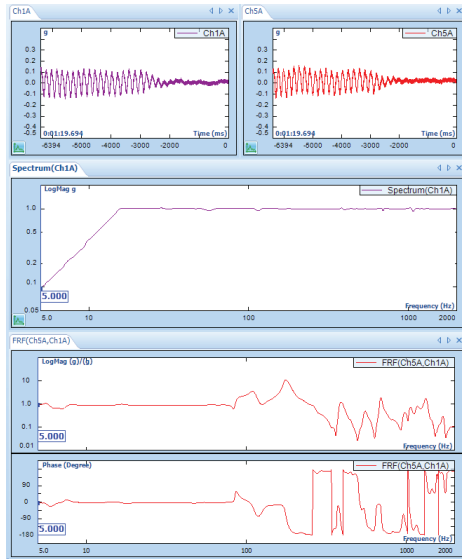

### Real-time Sine Reduction

Real-time sine reduction offers a solution to extend the number of measurement channels of a vibration controller system in a swept sine test. This software is run by a Spider system while an independent vibration controller controls the shaker. The sine reduction application calculates the same time and frequency functions as the controller, but using its own input signals. This function requires a COLA signal from the vibration controller system for instantaneous frequency, phase detection, and spectrum analysis.

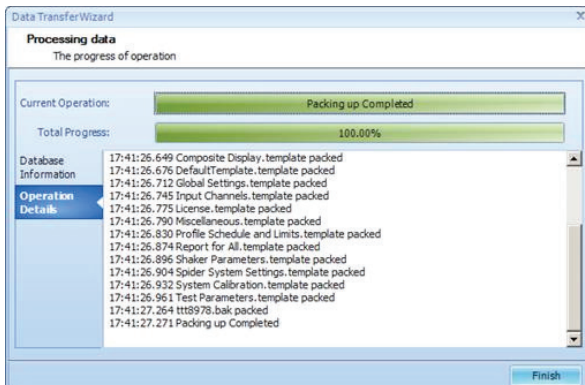

### Data Transfer Tool

Data Transfer Tool is installed with EDM. It transfers all EDM databases (including tests, parameters, and saved files) from a local computer to another over LAN or storage media (e.g. flash drive, DVD, ...). In addition, databases can be transferred between SQL server instances. The transfer and receive process can also be seen as a backup and recovery process. The step by step wizard guides through the whole process and make it easy to use.



### Sensor Calibration

The Sensor Calibration tool is used to calculate the sensitivity of sensors while the measurements of the sensors are compared against referenced sine-wave input signals. The user enters the following information: calibration signal nominal frequency, either RMS reading or dB RMS, and a reference (0 dB) value. The front-end automatically calculates the RMS levels and updates the sensitivity table. The user accepts or rejects the calibration results and views the reports.



### Versatile Report Functions

In the EDM software, the report function allows users to create a report in several formats including OpenOffice, XML, Microsoft Word, ActiveX and PDF. The report is template-based and completely customizable.

Users can customize the logo, margins, orientation of the paper, font, and the content. Microsoft Word/Office does not need to be installed in order to create reports. In Review Mode, batch reports can be made for the signals saved in multiple runs. Using ActiveX reporting, signal displays in the report can be rescaled, analyzed, and zoomed.

- User can select from various templates for creating reports
- Plot reports can be generated by simply right-clicking the mouse
- Company logos can be inserted into the template header or footer
- Reports can be in WORD, XML or PDF format
- “Active Report” allows the user to ZOOM in and out like a graph on the report
- Generate typical hardware calibration reports

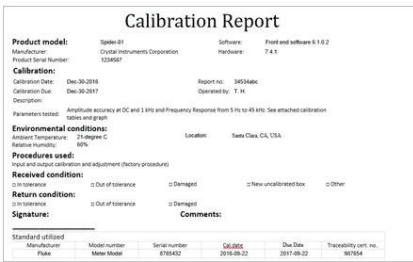

### Front-End Calibration Tool (FECT)

All products are calibrated at the factory prior to shipping and should be recalibrated annually by a factory authorized calibration service. The optional calibration tool existing before EDM 6.1 release is replaced by FECT, which includes manual calibration and factory calibration functions. The manual calibration provides basic adjustment and is operatable by either the user or a calibration specialist. The factory calibration provides as found and as left data measured at different frequencies and the report includes more comprehensive information about the calibration. The factory calibration requires designated meter model and should be performed by a calibration specialist.

FECT Functions: The software calibrates the signal source and adjusts the DC and AC gains and offset. It also calibrates the input channels at all coupling types and adjusts the DC and AC error. The report includes the model number, text for the calibration meter, and the calibration operator's name. The report is viewed and printed from the host PC.

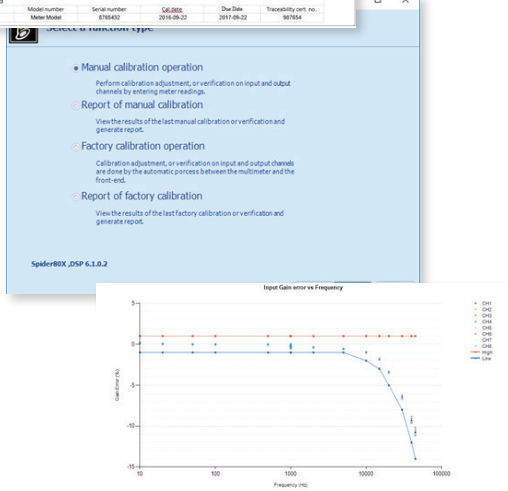



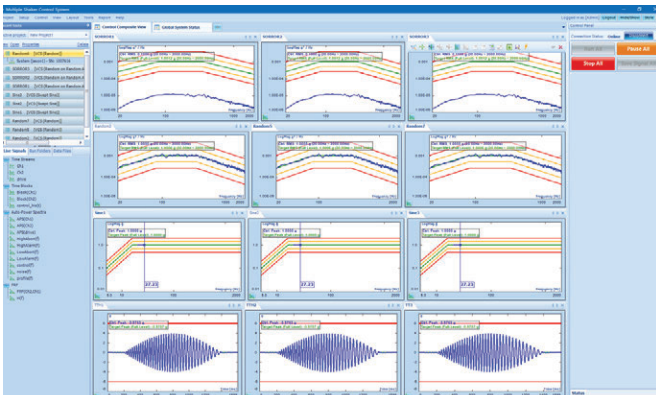

## Multi-Shaker Control from One Application

The multi-shaker control function is specifically designed for production applications, where the operator wants to observe and command multiple shaker tests from one PC station. The operator can manage the entire testing configuration from one EDM instance at their workstation – this includes observing the testing status, viewing individual signals from different shaker systems, and sending commands to each controller. Spider systems are not limited by bandwidth in their number of controllers – the ethernet connectivity of Spider systems allows for any number of connections. For practical reasons we limit the number of controllers that EDM can access to 12.

### Customizable Status Display

The status display for each individual shaker controller can be customized. For example, you can display the Peak value for a Sine controller and the RMS value for the Random. These can be displayed on one screen.

### Customizable Individual Command Panel

Commands for each controller are customized. Some panels can have Start/Stop/Pause, and other panels can show Sweep Up/Down.

### Run Different Type of Tests

Different types of tests can be mixed and loaded into this application together. Random, Sine, TTH or Shock can run in the same test duration.

### Common Commands

Several common commands have been implemented – these commands can be applied to all controllers at once. All the tests can be started or stopped by pressing one button.

### Robust Tolerant Design

Robust software design allows for tests to be run without being interrupted by the failure of other tests. If one test failed for any reason, the other tests will continue, until the operator wants to stop them.

$$\begin{Bmatrix} c_1(f) \\ c_2(f) \\ c_3(f) \\ c_4(f) \end{Bmatrix} = \begin{bmatrix} h_{11}(f) & h_{12}(f) & h_{13}(f) & h_{14}(f) \\ h_{21}(f) & h_{22}(f) & h_{23}(f) & h_{24}(f) \\ h_{31}(f) & h_{32}(f) & h_{33}(f) & h_{34}(f) \\ h_{41}(f) & h_{42}(f) & h_{43}(f) & h_{44}(f) \end{bmatrix} \begin{Bmatrix} d_1(f) \\ d_2(f) \\ d_3(f) \\ d_4(f) \end{Bmatrix}$$

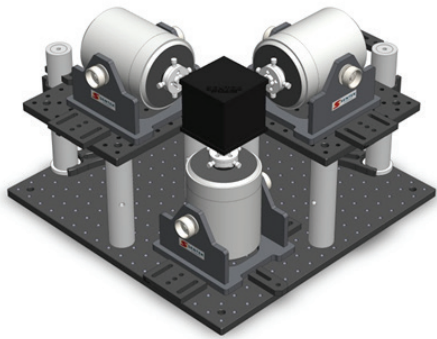
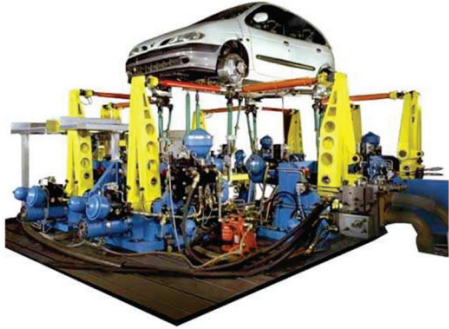

## Multi-Input and Multi-Output (MIMO) Control

Spider system recreates multiple degree of freedom environments in the laboratory. Applications include the dual shaker setup to either push-and-pull or simultaneous excitation in the same direction, or a complex system shaking a large structure in 3 axes simultaneously, or those driving a very heavy structure in one axis while sharing the load over many shakers.

In a Random test, MIMO produces true Random with one control per actuator or averaged control points per actuator. The same quality of control offered by MISO Random is inherent to MIMO Random control. Adaptive control guarantees rapid equalization and accurate control in the face of non-linear response. It also reduces the time required to achieve full level testing, which reduces the exposure to low level energy for the test article.

MIMO Sine, like MIMO Random, can control phase between actuators and between axes.

By maintaining a multi-dimensional impedance matrix, Spider system is always capable of determining the contribution from each shaker to the overall response and properly differentiating for each actuator so that proper, accurate, safe control is assured. The complex issue of singularities is addressed with an elegant solution that permits intricate tests to be performed without having to resort to test segmentation in an attempt to avoid the singularity.

For detail availability of MIMO control product line, please contact CI sales office.



## CoCo-80X Handheld System

### Dynamic Signal Analyzer & Vibration Data Collector

The CoCo-80X is a new generation of handheld data recorder, dynamic signal analyzer and vibration data collector from Crystal Instruments. Building on the success of the original CoCo-80, the new CoCo-80X boasts improved speed, a bigger screen, and more connection options. A significantly more powerful processor frees DSP resources for faster, more reliable, and more complex processing in real-time.

The handheld system is equipped with a bright 7.0 inch color LCD display with multi-point touch functionality as well as a physical keypad. Flexible connections via a USB 2.0 port, 100Base-T Ethernet port, 802.11 b/g/n optional Wi-Fi connection, SD card interface, HDMI interface, CAN-bus/serial port, stereo headphone and microphone jack, and GPS. Connect the CoCo-80X to a PC to download files, remotely control operations, or upgrade the software through several means of network connections.

The CoCo-80X is equipped with 8 software-enabled input channels. A unit initially purchased

as a 2 channel CoCo-80X can be remotely upgraded to 4, 6, or 8 channels via purchased upgrades. Each analog input is serviced by two 24-bit ADCs and a DSP implementing the cross-path calibration technology of US Patent number 7,302,354 B2 to achieve better than 150 dBFS dynamic range. Measured time histories can be recorded in 32-bit single precision floating point format and all subsequent signal processing is performed using floating-point arithmetic. 54 sample rates from 0.48 Hz to 102.4 kHz are provided with better than 150 dB of alias-free data.

The (ISO 11898-1&2) CAN-bus digital input allows simultaneous measurement of an automobile's speed, engine RPM and/or any of the hundreds of performance variables tracked by its Controlled Area Network (CAN). An embedded signal source channel provides several standard waveforms that are synchronized with the input sampling rate. A tachometer channel can be enabled to measure the rotating speed during data acquisition.

#### CoCo-80X Highlighted Features

|                              |  |
|------------------------------|--|
| 2-8 Inputs with IEPE         | Full Speed Recording                                       |
| Battery Powered (Portable)   | CAN-Bus, USB, HDMI, GPS, Audio, and Wi-Fi*                 |
| Patented Dual-AD Technology  | Large Touchscreen with Vivid Color Display                 |
| 150 dBFS Input Dynamic Range | SD Card for Mass Data Storage                              |
| 20 Volt Input Range          | Hard Keys for Quick Access                                 |
| 102.4 kHz Sampling           | <i>*Non Wi-Fi &amp; Non GPS Options Are Also Available</i> |





The CoCo-80X hardware platform supports three different software working modes: Dynamic Signal Analyzer (DSA), Vibration Data Collector (VDC), and CoCo Real-Time (CRT) mode. Each working mode has its own user interface and navigation structure. DSA mode is designed for structure analysis and mechanical testing. It is useful for electrical measurement, acoustic analysis, and a wide range of other applications. VDC mode is dedicated to route-based machine condition monitoring, vibration data collection, and trending. CRT mode allows the instrument to be operated as a bench-top testing device where

commands are executed and data is displayed in real-time on an accompanying PC.

The CoCo-80X supports multiple languages that can be switched dynamically. It comes with English, Chinese, Japanese, French and Spanish.

The CoCo-90 is separate model that mainly targets at general data acquisition. It is equipped with 16 input channels employing LEMO connectors.

#### CoCo-80X Featured Benefits

Ultra-Portable for Field or Lab Use

Data Recording & Real Time Measurement Available in One Box

Speeds Time From Data Acquisition to Analysis

Super High Dynamic Range Eliminates the Need of Input Range Setting

Dual User Interface for Both Lab User & Field Route Data Collection



## Configurable Signal Analysis for Dynamic Signal Analyzers

Configurable Signal Analysis (CSA) is a new concept introduced and adopted by Crystal Instruments in its newest generation of dynamic signal analyzer systems, including the CoCo-80X. It allows the user to dynamically configure the DSP (Digital Signal Processing) functions so that the data processing flow can be customized from application to application. The result is a portable, customizable handheld signal analyzer which includes specialized, powerful functions while maintaining a very clean and simple user interface for day to day operation. CSA is a unique feature that is currently available only in Crystal Instruments products.

Unlike the traditional approach, CSA is user customizable. With CSA, the user can flexibly apply various math operations to live data streams without changing the installed program. The processing algorithm is a combination of user customizable math functions. Most of

these algorithms are fairly simple, such as add, subtract, multiply and divide operations. Some others are very sophisticated, such as calculating the Frequency Response Functions (FRFs), between all the channels. The user can choose and apply the analysis functions of their choice, or combine them to meet their particular needs. The user can also cascade these algorithms in sequence combining several functions to generate a very advanced new function. With this approach, the CoCo DSP systems are enabled with “unlimited” application functionality.

### CSA Editor

Customization of a CSA script is done within the CSA Editor which is integrated into the Crystal Instruments EDM software. The CSA Editor uses an intuitive drag and drop graphic interface that makes configuring the CSA an easy-to-learn visual process.





## Vibration Data Collector

The CoCo-80X operates in either Dynamic Signal Analysis (DSA) or Vibration Data Collector (VDC) mode. Each working mode has its own user interface and navigation structure. VDC mode is dedicated to machine vibration data collection, analysis, and trending. It provides both route based data collection and onsite measurement functions.

The route based data collection mode includes: overall readings, time waveform, spectrum and demodulated spectrum. Onsite measurement

mode conducts following test in addition to the data collection functions: bump test, coast-down / run-up, and balancing.

Crystal Instruments' data collection system consists of the portable CoCo-80X data collector and the Engineering Data Management (EDM) software, designed specifically for use in industrial and manufacturing plants to acquire, analyze, and maintain data related to improving and optimizing the reliability and performance of rotating machinery.

### Route Based Condition Monitoring

Measurement Channels: 1 or 3 channels (tri-axis) with tachometer enabled or disabled  
Route Collection control: Easy navigation from the UI level to routes. View or hold live signals, review measured record, previous measurement entry, next measurement entry, previous point, next point, point and route management.

### Demodulated Spectrum

Available in both route collection and onsite mode Demodulation Bandwidth: 24 bandwidth options ranging from 125 Hz – 1.44 kHz, to 32 kHz – 46.08 kHz.

### Coast-Down/Run-Up

The following measurements can be made in the Order Tracking option: Raw time streams, real-time order tracks and order spectra, narrow band RPM spectra and fixed band RPM spectra, overall RPM spectrum, and order tracks with phase relative to tachometer signals.

### Rotor Balancing

Enables users to correct the imbalance without dismantling the machine. It is possible to balance rotors of any size with either 1 or 2 place balancing. Using the multiple channel option, parallel measurements on 2 sensors are possible, resulting in a faster, safer, and more accurate procedure. The user interface allows stopping and starting balancing as needed and to repeat any single operation without running the whole procedure.



8 Channel Configuration of CoCo-80X

## CoCo-80X Specifications

The CoCo-80X is equipped with 2, 4, 6, or 8 software configurable input channels through BNC connectors. The removable SD card can record 8 channels of streaming signals simultaneously (up to 102.4 kHz) while computing real-time time and frequency based functions. An embedded signal source channel provides various signal output waveforms that are synchronized with the input sampling rate.

### Inputs: 2, 4, 6, 8 channels

Up to 8 BNC connectors, built-in IEPE current source, single-ended or differential, AC, DC coupling, 150 dBFS dynamic range, dual 24-bit A/D converters, input range  $\pm 20$  Volts

### Output

1 LEMO connector, 100 dB dynamic range, 24-bit A/D converter

### Tacho

1 LEMO connector: Tachometer Type 1 and 2 share one LEMO connector and can be selected by the software **Interface**

### Ports

100 Base-T Ethernet, Wi-Fi, GPS, Mini-USB 2.0, SD Card, Audio input and output, CAN-Bus

### Maximum Sampling Rate

102.4 kHz simultaneously for all inputs

### LCD

7" color TFT WVGA display 800x480 resolution with P-Cap touch screen, 1300 NITS

### Dimensions

229 x 172 x 65.5 mm (L X W X H)

### Weight

1.96 kg including battery

### Power

Power Input: DC power 15 V ( $\pm 10\%$ )/3A  
 Max Power Consumption: 14 watts, 8 watts with LCD off  
 Battery Operations: 6-8 hours

### Typical Real-time Analysis Functions

Math (+, -, \*, /), integration, differentiation, FFT, averaging, windowing, auto power spectra, cross spectra, FRF, coherence, real-time filters, RMS, octave, order tracking, swept sine, limiting, alarm/abort and more.

### Vibration Data Collection Functions

RMS, true-RMS, overall-RMS, waveforms, spectrum, demodulated spectrum, trending and alarm, 2 plane balancing. Measure acceleration, velocity, displacement and tachometer.



# CoCo-80X Hardware Diagram

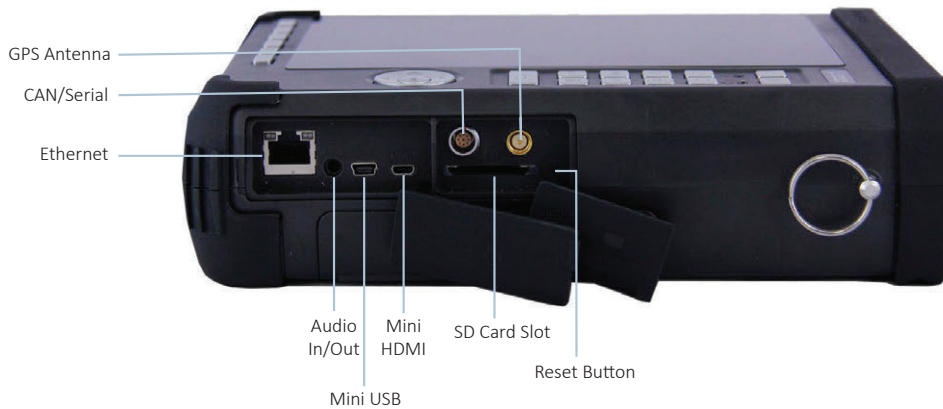



16 Channel Configuration of CoCo-90

## CoCo-90 Specifications

The CoCo-90 is equipped with 16 input channels employing LEMO connectors. It can accurately measure and record both dynamic and static signals. The mass flash memory can record 16 channels of streaming signals simultaneously (up to 51.2 kHz) while computing real-time time and frequency based functions. An embedded signal source channel provides

various signal output waveforms that are synchronized with the input sampling rate. LEMO to BNC adapters are provided.

### Inputs of CoCo-90

16 LEMO connectors, built-in IEPE current source, single-ended, AC or DC coupling, 100 dB dynamic range, 24-bit A/D converters, input range  $\pm 10$  Volts





## Handheld Field Testing Solution Spider-20 Handheld Wireless Dynamic Signal Analyzer

Spider-20 is a compact yet powerful dynamic signal analyzer and digital data recorder. It provides four 24-bit precise high-fidelity input channels, and a unique software-selectable tachometer-input/signal-source output channel (all using conventional BNC connectors). Each input is individually programmable to accept AC or DC voltage or output from an IEPE (ICP) sensor with built-in electronics.

Spider-20 is a diminutive 5.3 x 4.3 x 1 inch tool weighing only 18 ounces. It has only three push-button controls and five LED status indicators. This little powerhouse can run over 6 hours on its internal rechargeable battery which can be replaced in field with a backup battery. It can also record data on its built-in 4GB flash memory at the simple push of a button.

Spider-20 communicates with the world through its built-in Wi-Fi interface. Use your iPad to setup and view or record time histories as well as perform spectrum analysis or measure Frequency Response and Coherence functions. Link the Spider-20 to your laptop or tablet running Windows and enjoy the full repertoire of

functionality provided by our EDM (Engineering Data Management) software including 1/nth Octave acoustic functions, Order Tracking for rotating machinery, Shock Response Spectra for drop testing, or Digital Filtering for special purpose analysis.

A secondary version, Spider-20E, replaces Wi-Fi with a wired Ethernet connection. The Spider-20E has the same form factor as the standard wireless version.

Transfer measured data to truly massive storage space using the EDM Cloud server. EDM can be used to program your Spider-20 to perform a custom measurement or measurement sequence at the touch of its START button, making it an unimposing and user-friendly tool. No computer, tablet or phone is required; just use your thumb and your Spider-20 operating in Black Box mode. Use our flexible Automated Schedule and Limiting software to turn this Spider into an intelligent unattended monitor capable of responding to data conditions or networked instructions, notifying you of significant conditions via e-mail.



## Industry and Product Applications

### Machinery Diagnosis

Four inputs and a tachometer channel are the perfect size for many machinery monitoring tasks. Simultaneously measure two perpendicular proximity probes or horizontal and vertical bearing cap accelerations at both ends of a machine. Record this along with a 1/ rev tachometer during startups and shutdowns to plot waterfalls and Campbell diagrams identifying resonances, critical speeds and unusual forcing functions. Use the same signal inputs to balance the machine. Place accelerometers on either side of a coupling to aid alignment.

### Machine/Process Monitoring

Load a custom monitoring program employing our Automated Schedule and Limiting software and leave your Spider-20 to monitor speed and four dynamic inputs. Upon detecting an alarm-level limit (in the time or frequency domain), it can send you an email reporting the finding and make an immediate recording for more detailed analysis. For longer stays, leave the accessory AC power unit plugged in. This allows Spider-20 to draw power (6 Watts, maximum) from any 100 to 240 VAC (50/60 Hz) power line. Alternatively, you can provide a battery backup of 15 VDC ( $\pm 10\%$ ) for more remote applications.

#### SPIDER-20 & SPIDER-20E PRODUCT HIGHLIGHTS

|                                |                      |                     |
|--------------------------------|----------------------|---------------------|
| Weighs only 18 Ounces          | 4 GB Flash Memory    | PC Independent      |
| Built-In Wi-Fi (Spider-20)     | 4 Input Channels     | iPad Compatible     |
| Built-In Ethernet (Spider-20E) | 1 Tachometer Channel | 6 Hour Battery Life |





## Octave Analysis & Sound Level Meter

### Acoustic Measurements with the Spider Series

Acoustics measurements are performed for a variety of reasons, including: product design, production testing, machine performance, and process control. Crystal Instruments' Spider series has capable acoustic measurement facilities including real-time octave, 1/3 octave filters, and sound level meter functions. Crystal Instruments provides an easy to use yet powerful toolbox for acquiring and viewing acoustic signals. Digital octave band filters and raw time data recording can be performed simultaneously for a detailed investigation of noise problems.

The Spider series meets the requirements for measurements from 4 input channels going up to 512 channels!

Onboard IEPE (ICP®) transducer power capability allows for direct connection to pre-polarized microphones when used with an ICP microphone preamplifier. Traditional condenser microphones are also easily accommodated by connecting the direct voltage signal from the microphone power supply into an input channel. White and pink noise signals can be produced using the waveform generator. This feature is very useful when performing absorption measurements using a speaker.

#### Real-time Octave Analysis

The acoustic data acquisition software option for

Spider hardware includes real-time octave filters, sound level meters, and microphone calibration functions. These three operations allow users to perform many acoustic measurement operations.

The octave analysis option applies a bank of real-time filters with 1/1, 1/3rd, 1/6th, or 1/12th octave resolution. The input time stream is split into fractional frequency-band signals (octave bands) which can be saved. Frequency weighting can be applied to the octave bands to simulate human hearing, and time weighting can be applied to adjust sensitivity to short duration events. The resulting octave spectra can be saved periodically and displayed on a waterfall plot to observe how the spectrum changes in time. The RMS time history can also be saved as a time trace of a given octave band.

The 1/1 and 1/3 octave analysis is implemented using a real-time band-pass filtering with decimation technique. The data stream is processed continuously, and fed into a bank of decimation filters. Band-pass filters are then applied to the output of each stage of the decimation filters. This provides extremely accurate filter shapes that comply with worldwide acoustic standards: ANSI std. S1.11:2004, Order 3 Type 1-D and IEC 61260-1995.

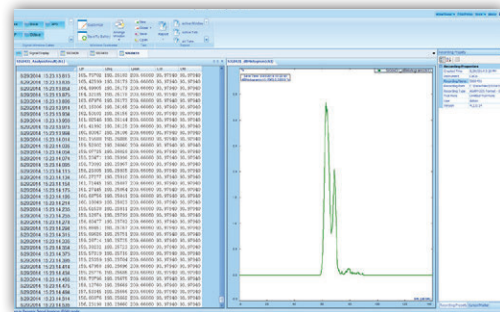
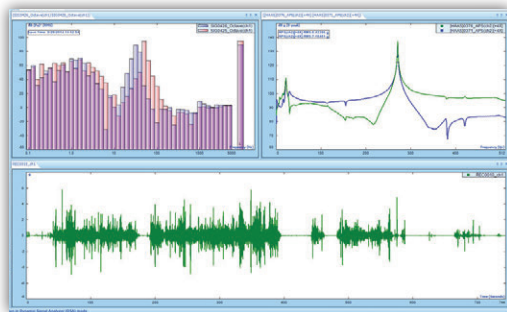
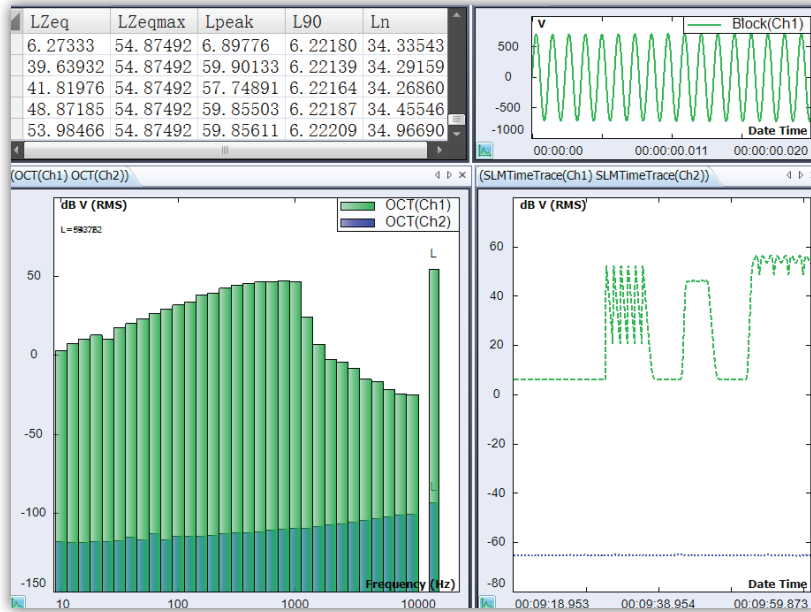

### Acoustic Measurement: Sound Level Meter

The Sound Level Meter (SLM) is a related application in the acoustic data acquisition software. This module is also referred to as an Overall Level Meter. The SLM applies a frequency weighting filter to the input signal and time weighting to the filter's output. Various acoustic measurements are then extracted from both the input and output signals of this frequency weighting filter.

All of the features that you would expect from an acoustic measurement device are present... and then some! A, B, C, and linear weighting functions; fast, slow, impulse, and peak detectors; and user selectable high and low-pass filtering. The tremendous dynamic range that all Crystal Instruments products offer take the worry out of setting voltage ranges precisely to avoid under-range or overload conditions.

### Built-in Microphone Calibration

Microphone calibration is easily handled by using

a traditional microphone calibrator together with the online calibration feature. Simply define the frequency and amplitude of the reference signal, and the Crystal Instruments system will automatically detect the input channel that the calibration signal is applied to and then calculate the necessary calibration constants. Offsets are calculated and stored for later reference.

### Simultaneous Recording and Octave Analysis

The Spider series is designed with simultaneous time-stream recording capability. While the acoustic analysis is processed in real time, the raw time data of the Spider can be recorded into internal flash memory or an external dedicated Spider-NAS storage device.

The raw time data of all input channels can be recorded at full analysis frequency band. After recording, the saved files can be processed by using EDM Post Analyzer which provides the identical analysis algorithm to those available in the real time mode.



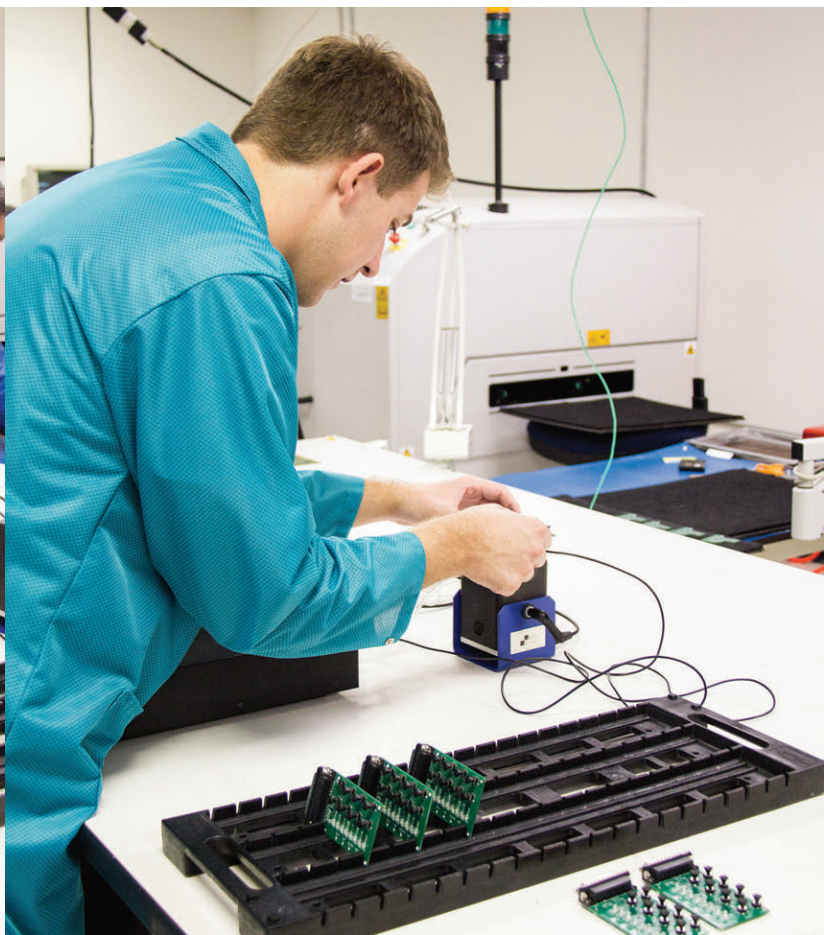
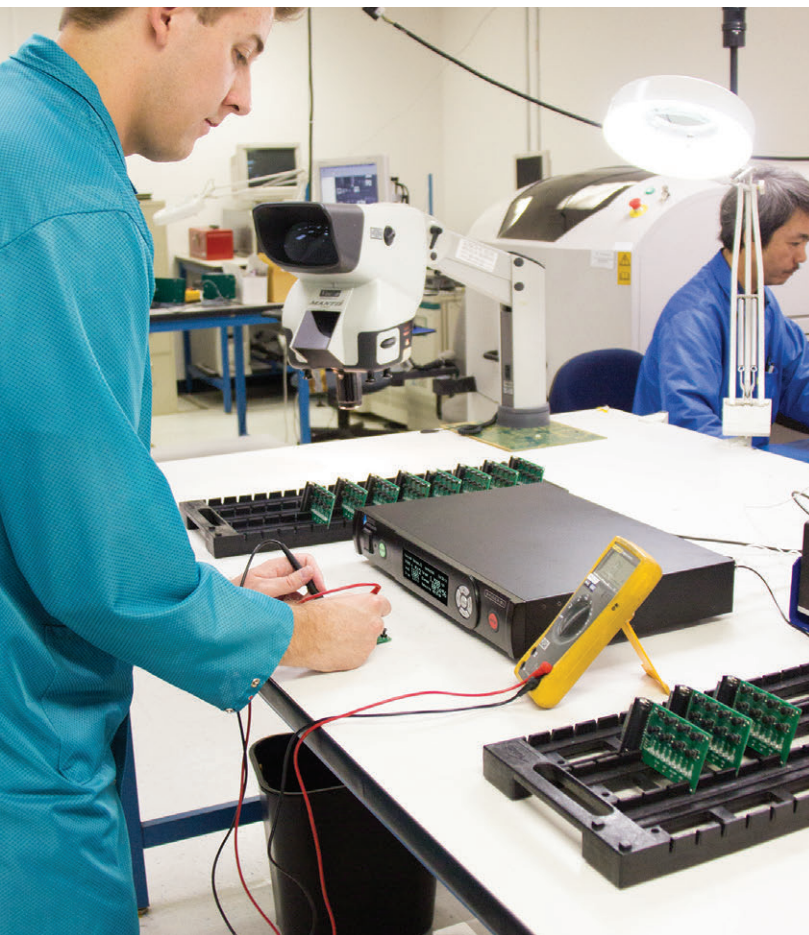

## Automated Production Testing Solutions

Automated production testing is critical in today's competitive manufacturing environment. Companies can no longer rely on variable costs, non-uniformity, and potential health hazards that come with a laborer-based manufacturing line. This is no less true for sound and vibration tests, ranging from in-process burn-in tests to product validation and verification tests. The measurement tools and intelligence behind present day manufacturing include data acquisition equipment as well as closed-loop control. And while these systems may not take part in the assembly of any goods, they are just as important to ensure quality control for both components coming into an assembly line and products going out.

Crystal Instruments has evolved a synergistic solution to such testing involving custom hardware and application-focused software. The Spider-80X system is a complete multi-channel analyzer/controller with IEEE 1588 Precision Time Protocol (PTP) Ethernet communication.

It can be programmed to accomplish multiple complex measurement tasks using a workstation or PC in combination with Engineering Data Management (EDM) software. Thereafter, the PC can be (optionally) disconnected and tests run in "Black Box" mode without an attached computer. Control of the Spider front-end may be accomplished through an Apple iPad™ tablet using the EDM App for iPad.

EDM serves as the standardized human interface to all Crystal Instruments' vibration control systems (VCS) and dynamic signal analyzers (DSA). Regardless of the specific application, channel count or language (English, Japanese, Chinese, Russian) the user interface presents the same "look and feel". Through EDM, the user can create custom interfaces and greatly simplified operating interfaces for specific product tests. Users can also generate custom reports using XML, OpenOffice, PDF, and Microsoft Word templates.

**Step 1:**  
EDM sets the alarm limit together with a special message string, such as "Exceeding Limit".

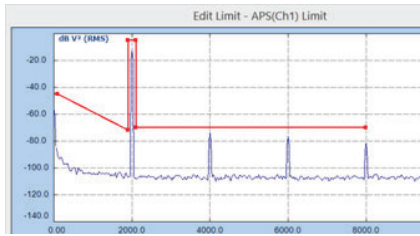

**Step 2:**  
When an alarm event happens, the customized string, "Exceeding Limit" will be sent to the EDM Cloud email service.



The Spider API is the gateway to integration with LabView, Matlab and other scripting software. Spider front-ends operate from Android, Linux and iOS in addition to Microsoft Windows. A single iPhone, tablet or PC can control multiple Spider front-ends at distributed locations running disparate tests from a single control screen.

Event-Action Rules (EAR) allows users to customize the system's response to every test event. User defined events include: signal exceeds a limit profile, signal is less than a limit profile, normal end-of-test, loss-of-signal or any of number of the events encountered during a VCS test. Responses include: halting a test, starting a different test, flashing the control screen, initiating a recording, sending a screen message, sending a text message, or sending an email. Users can program loops using EAR. Every event is logged on a cloud server and is identified by the text of a customized event string (only on EDM Cloud).

Limit Testing (LT) may be applied to a Time Block, Auto Spectrum, FRF, Coherence, Octave Spectrum, Sound-Level Measurements, RMS or Peak value. Spectra and time histories are tested by comparing against a custom test signal; a

**Step 3:**  
User will receive an alarm email

EDM or EDM  
Cloud Email  
Service



*Testing status can be viewed on any PC, iPad or even smart phone.*

template which must bound the measured signal. Each test signal may be either an upper or lower limit and may contain up to 64 segments. Up to 64 test signals may be applied to a single measurement.

Burn-in testing for electronic products is a type of testing that is easily automated with sound and vibration instrumentation. For example, consider cell phones, a consumer product produced in the thousands which contains both a microphone and a speaker. These two audio components almost always need to be run through a burn-in test, which is easily automated using the Spider-80X. The Spider-80X provides a stimulating programmable function generator and data collecting input channels.

The methods for testing vary but the principles remain the same. One of the two output channels of the Spider-80X runs through a series of tones or pulses to test the phone's receiver while the input channels listen to a prerecorded sound clip played out through the speaker. Either time waveform data or spectral data can be collected and pass/fail tolerances set within Crystal Instruments Engineering Data Management (EDM) software.



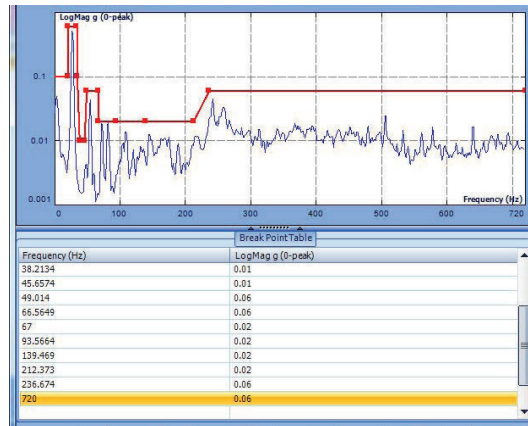

Limit signals display

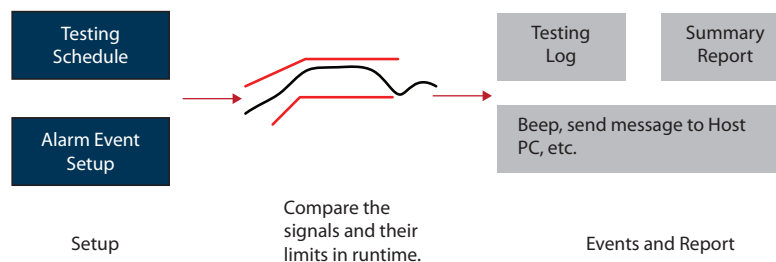

An illustration of the automatic testing process.

Scalability is one of the benefits of automation and this is why the Spider-80X is designed as a networked device. With an Ethernet connection on the Spider-80X, multiple front-ends are connected to test tens if not hundreds of cell phones at a time. This may seem a bit excessive until one considers using not just a single microphone per cell-phone but rather using a microphone array to capture and map a planer response or even a 3-dimensional hemisphere of sound around the cell phone.

However, burn-in tests are not the only type of automated production tests performed with sound and vibration instrumentation. Product validation and verification are also an important part of production line testing. Such tests range from validating incoming components to verifying a finished product assembled from them.

Virtually all turbine manufacturers carefully match-tune the component blades of their steam and gas turbines. This involves accurately measuring the natural frequency of one or more vibration modes of each blade individually, while the blade is root-restrained by a standardized fixture. Different manufacturers implement such tests in various manners, but all rely upon measuring

the forced vibration response of the blade. The most accurate frequency determinations are made from frequency response functions (FRF), wherein both the stimulating force and resulting vibration are simultaneously measured.

Other products are quality-audited for consistent natural frequencies, to indicating consistent geometry. Often, the damping factor of each mode is also measured and used as an indication of proper assembly and freedom from cracked components. As an example, large artillery shells are impulse-tested using an instrumented hammer and a microphone. When struck, the shell rings like a bell. Each shell must exhibit natural frequencies within an acceptable scatter-band. Shells with high damping factors are subsequently inspected for cracks.

Frequency response functions characterize the linear relationship between a measured input and output and conveys an enormous amount of information. An accompanying two-channel measurement, the coherence function, determines if two signals are linearly related. It is an ideal indicator of throughput linearity, an important characteristic of most electronic circuits and many mechanical structures.

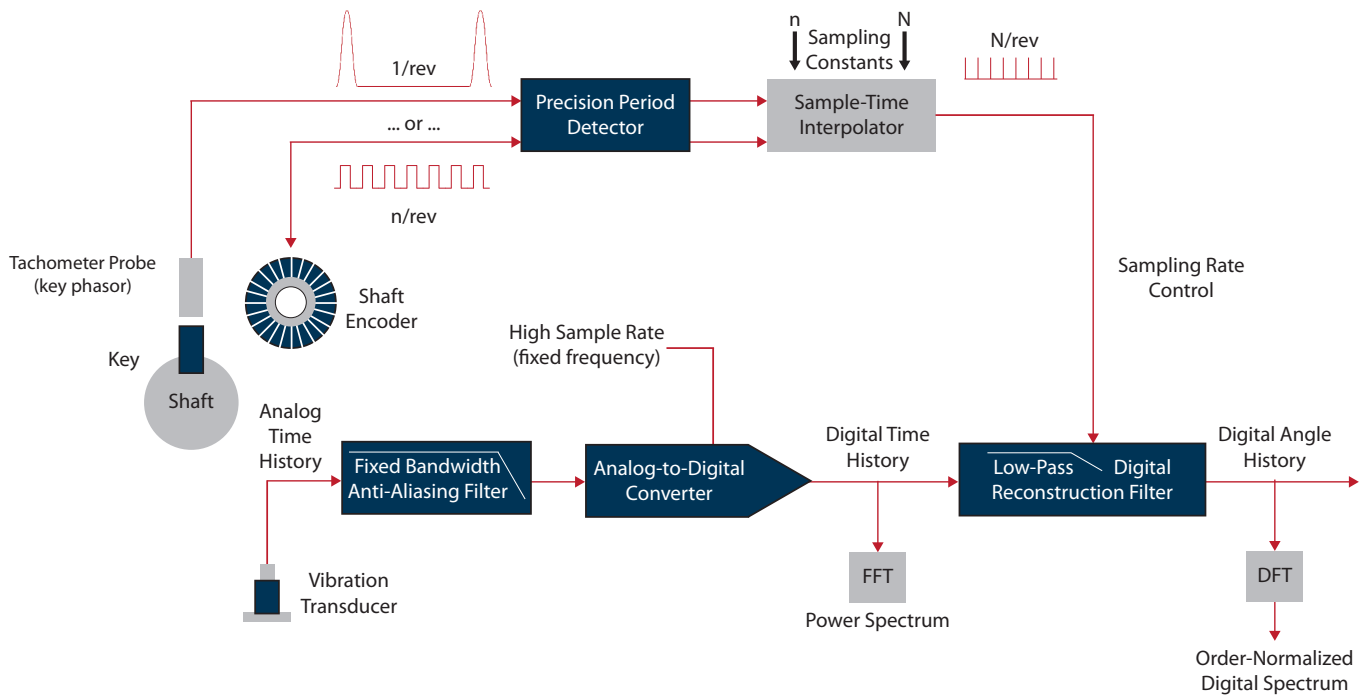

## Rotational Dynamic Acquisition & Analysis

### Providing Real-time Order Tracking

The high channel count Spider systems provide a wide range of real-time order tracking capability to understand the noise and vibration induced within rotating and reciprocating machines. Fixed and variable speed machines are accommodated as are both structural vibration and condition monitoring diagnostics. Multiple tachometer inputs can be processed for accurate speed tracking during analysis. Spectral mapping, order tracking, time history and orbit data analysis are all available.

Additionally, Crystal Instruments provides post processing order tracking capability in its Post Analyzer (PA) that generates the same analysis results as real-time order tracking. The user can simply record the raw data together with tachometer signals and process them later.

### Advanced Digital Processing

All measurements in the order domain are derived from an advanced digital resampling method. High speed DSP processing allows synchronization of the analyzer's sampling rate to a tachometer signal. The analyzer's sampling rate continuously adjusts to track variation in shaft speed. After data sampling, a flexible radix FFT converts the time/angle data into the frequency/order domain. The flexible radix algorithm provides a much

broader choice of resolutions and spans than does a power-of-2 FFT for extraction of the order amplitude values as a function of RPM.

Order tracking extracts the amplitude at a single order and plots it against machine speed (RPM). Real-time order tracking offers advantages over fixed sample rate techniques. It provides better tracking performance when the RPM varies quickly. Additionally, it provides precise control over the order resolution of the measurement. For instance, users can specify that the order resolution be 1/10 of an order for all measurements.

There are also significant benefits in order amplitude estimation provided by the real-time order tracking method. Since the sampling rate is synchronized to the tachometer signal, the data in each frame is always exactly periodic with respect to the fundamental speed. That is, there are always an integer number of cycles for the fundamental and its harmonics in each data frame. Because of this periodicity, there is no need to use a spectral window, such as a Hann window, in the tracking calculation. This results in a more accurate estimate of the amplitude for each order.

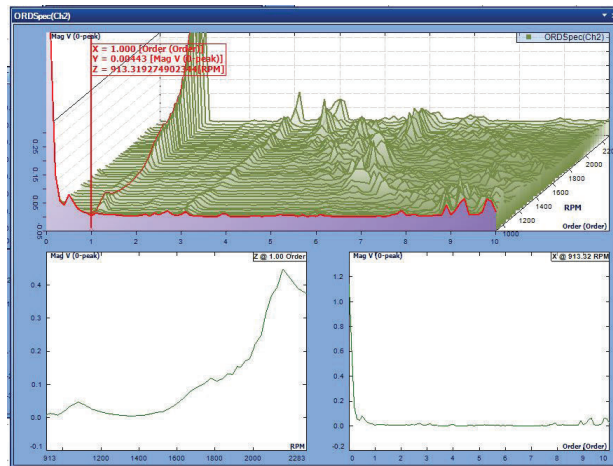
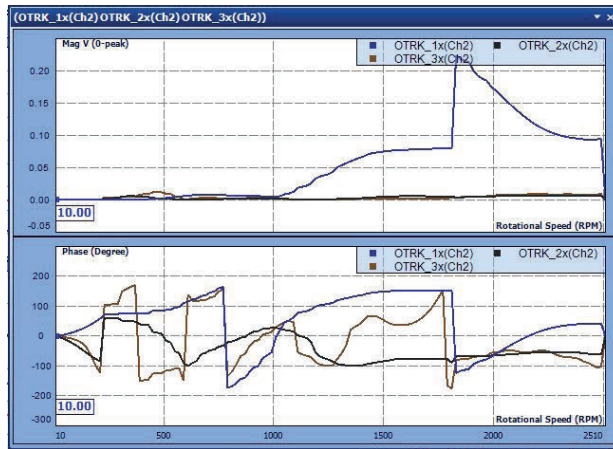

### Real-Time Order Tracks and Order Spectra

Real-Time order tracks are the amplitude history signals of certain “rotational orders” graphed against the machine’s RPM. Multiple order tracks can be measured, displayed, and saved. Order spectra are auto power spectra that are normalized to orders. All order tracks can have the optional phase which is phase measurement relative to the tachometer signal.

The RPM range can be from 10 to 10,000. The acquisition modes include: Free Run, Run Up, Run Down, Run Up and Down, Run Down and Up order tracks can be scaled with linear peak, linear RMS, or power scaling.

### Constant Band Frequency Spectra

Constant band frequency spectrum displays the auto power spectrum of the selected fixed band of frequencies and is computed using FFT analysis within the fixed band of interest. 3D plots using time or RPM as the reference are available along with 3D extractions of desired orders of interest.

The available spectrum amplitude units includes EU<sub>pk</sub>, EU<sub>rms</sub>, EU<sup>2</sup><sub>rms</sub>, EU<sup>2</sup>/Hz, and EU<sup>2</sup>•s/Hz

### Order Tracks with Phase

Order tracks with phase are order spectra with the associated phase measurement relative to the tachometer signal. All the measurement specifications are the same as real-valued order tracks, except that order tracks with phase can also be displayed as Bode, Polar, or Nyquist plots. Furthermore, with this option the orbit display can be enabled for any two data channels.

### Tachometer Processing

The tachometer is stored as a time history. The user may view either the original tachometer input waveform or the resulting RPM-versus-time translation. A tachometer channel can be used to extract the order track of any input channel or channels. Tachometer signal processing automatically eliminates any “glitches” in the tachometer pulse train and reconstructs the best estimate pulse signal for phase measurement.

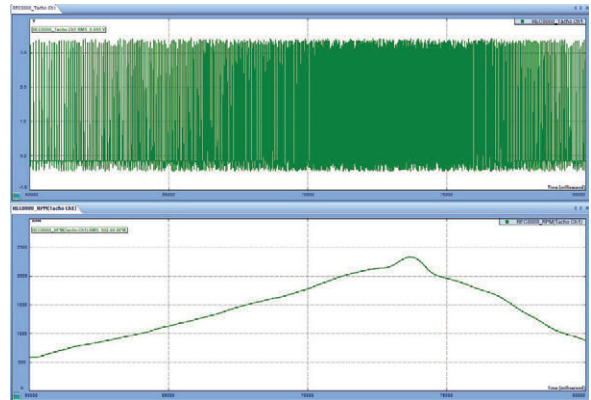
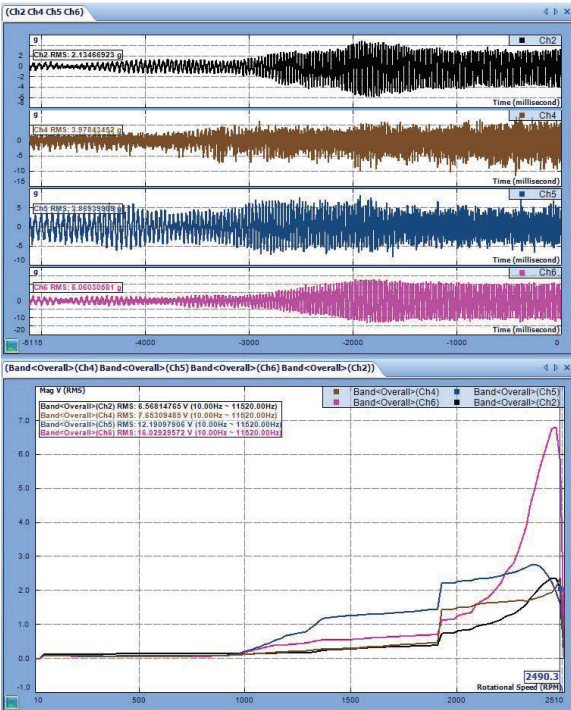

### Orbit Analysis

Online orbits can be displayed and monitored on a standard two-channel orbit diagram chart. For advanced analysis a throughput recording including a tachometer or vibration signal can be post-processed using the orbit analysis tool in Post Analyzer. This provides averaging, filtering and order based orbit displays with a replay feature for visualizing changes over a change in machine speed.

### Display Flexibility

Measurements can be viewed in real time as the data is being acquired and analyzed. On line displays include the time histories, orbit plots, order spectra, order tracks, waterfalls, spectrograms, and contour plots. Users can also view the instantaneous RPM as a function of time.

Waterfall displays provide a good overview of an entire run-up or run-down measurement. To better understand the measurement results, users can easily change the viewing angle so that effects of order related excitation and structural resonance

excitation are immediately obvious.

Waterfall displays include a “slice” mode that provides a plot of a cut across the order or RPM axes. To view a particular slice, simply position the 3D cursor. Users can view the order track for a given order, or fractional order, or view the amplitude-versus-order spectrum at a given RPM. This capability allows the user to quickly zero in on the problem’s root cause.

Color map presentations further enhance problem diagnosis capabilities. For example, spectrograms, or color intensity plots make it very easy to differentiate order related responses from excitation due of a structural resonance. Color contour, or topographic maps, also provide added graphic insight into the nature of a vibration or acoustic response.

A full complement of cursors – single, dual, peak, valley, harmonic and sideband provide precise numeric readout of critical data features. Users also have complete and easy control of the orientation, scaling, colors, etc., enabling the creation of insightful data visualizations.





## Spider-80SG General Data Acquisition & Strain Measurement

The Spider-80SG is a high precision, general purpose data acquisition device featuring strain gage functionality. This device can be used in a variety of physical and measurement tests. The Spider-80SG can acquire data from a strain gage or a wide range of measurement quantities. A variety of general purpose and strain gage based sensors are supported. The Spider-80SG is built on the proven outstanding performance and reliability of Crystal Instruments' DSP-based hardware platform. It features the same form factor as other Spider-80X front-ends from Crystal Instruments and can be configured into one measurement system with excellent compatibility and scalability. This gives the Spider-80SG capabilities to reliably acquire data from multiple sensors and for multiple measurement quantities simultaneously.

The Spider-80SG front-end connects to the network switch of a PC using an Ethernet connection. When used with a strain gage, it measures the strain based on arriving signals, measuring the changes in resistance when the strain gauge is stretched or compressed. It can also be used to measure Force, Torque, Pressure, Acceleration,

Velocity and Displacement. The Spider-80SG can be configured to output an excitation voltage to power up the sensors and measure a range of measurement quantities.

Pluggable front-ends provide the system with maximum flexibility of analog channel configuration, making it ideal for a range of measurement tests under various circumstances. The modular design allows configurations with 8 input channels of isolated analog inputs and one analog output.

With Crystal Instruments' unique Ethernet based time synchronization technology, multiple Spider-80SG front-ends can be chained together to construct a system with higher number of input channels. High channel systems scale up to 512 channels.

Each Spider-80SG front-end has its own mass storage media that houses the operating software and stores measurement data. This truly distributed system guarantees data recording at full speed without being subject to network speed limitations.

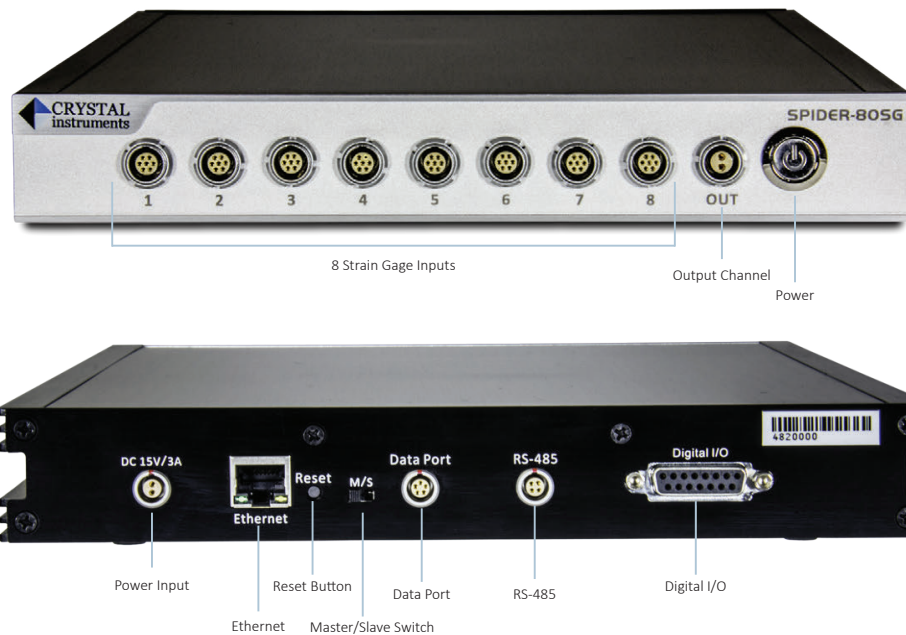

## Product Applications

### Dual Modes of Excitation

The Spider-80SG is equipped with dual excitation modes. There is an option for Precision Excitation Voltage of  $\pm 2.5V$  or  $\pm 5V$  that can be used to excite a strain gage or a strain gage based sensor and measure the minute change in resistance accurately. It is also equipped with a user configurable DC power supply of 2.5V, 5V and 10V which can be used as an excitation voltage for a wide variety of sensors.

### Remote Sensing

The Spider-80SG has been tested to work on strain gages up to 1000 ft away from the analyzer using the remote sensing feature. Using an 18AWG 5 conductor cable to measure the excitation voltage using remote sensing and changes in output voltage, the error was measured to be less than 1.5% for up to signal frequencies of 10 KHz.

### Use with Vibration Controller

The Spider-80SG's compatibility allows it to be chained together with Spider-80X front-end(s), extending the capabilities of the Spider-80SG to read and record general purpose measurements simultaneously while performing a vibration control test.

### High Performance Hardware Capability

Since all the processing and data recording is executed locally inside the Spider-80SG, the front-end can be located far from the host PC and

closer to the test article. This flexibility in location prevents the measurement results from being affected by the network connection limitations and other environmental errors. This decentralized and distributed structure greatly reduces the noise and electrical interference in the system. One PC can monitor and control multiple Spider-80SG front-ends over the network. With wireless network routers, the PC can easily connect to the Spider-80SG remotely via Wi-Fi.

### Multiple Front-ends & Time Synchronization

The Spider-80SG is built on IEEE 1588 time synchronization technology. The Spider-80SG front-ends on the same network can be synchronized with up to 50 ns accuracy, which guarantees  $\pm 1$  degree cross channel phase match up to 20 kHz. With such unique technology and high-speed Ethernet data transfer capability, the distributed components on the network truly act as one integrated system.

### Black Box Mode: Run without PC

The Spider-80SG can operate in Black Box mode, which allows the measurements to take place without a PC. In this mode, a PC is used only to configure the Spider-80SG system before the system starts operating and to download data after the test is complete. During the test, the system can operate according to a preset schedule or is controlled from a variety of external devices, such as a tablet or iPad.

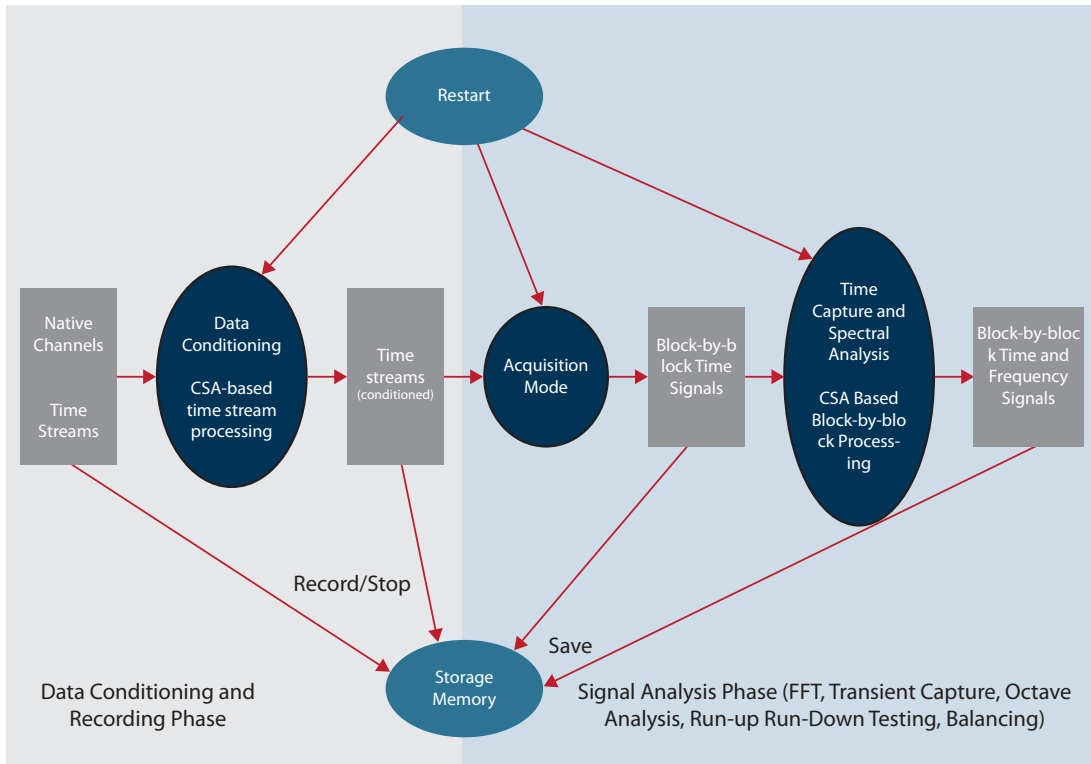

## Continuous Data Recording & Post Analysis

### Introduction

In a time-critical test, it is highly desirable to record the raw time data continuously, so that the data can be analyzed later when more time is available for a complete review. Integral raw data recording eliminates the need for a separate recording device so necessary just a few years ago.

The Spider platform simultaneously performs both real-time processing and continuous data recording. In most of real-time applications, the raw data can be recorded at any desired sampling rate with full 32-bit floating point precision. To increase the reliability of data recording, a special check sum algorithm is always applied to the measurements.

For example in a typical FFT process, the raw data time streams (full bandwidth, sampled at the instrument's highest sample rate) and/or the continuous output of a bandwidth-reducing data conditioning process can be recorded at a lower sample rate on the system's storage media while the real-time filtering and spectral analysis is in progress. This same design philosophy is incorporated in the Spider high channel count systems.

While being recorded, the measured values can be graphically displayed as y/t or y/x diagrams, as bar charts, as waterfalls, FFT, PSD, tachometer speed, or numerical statistics displays with a simple mouse-click. EDM software allows users to design an individual graphical visualization for each desired real-time measurement.

The recording system processes virtually every physical quantity, including: temperature, voltage, stress, strain, pressure, force, acceleration and frequency. Even high channel count applications using hundreds of channels can be configured within a very short time and are handled safely and efficiently.

The recording function is driven by user-defined events. On Spider front-ends the recording "action" can be initiated via various events, including: hard button press, user software command, defined trigger-condition event, digital input event, third party software command, defined alarm limit event, fixed timer, etc.



The Spider-NAS features eight dedicated high-speed data buses and a removable 250 GB serial ATA (SATA) Solid State Disk (SSD).

### High Channel Count Solution Using Spider Front-ends

For high channel count applications, the data recording can be realized on Spider systems via either of two approaches: record the time-stream data into the flash memory on each of Spider front-end or, record the time-stream data into an external storage device, such as the Spider-NAS. (One Spider-NAS can service up to eight Spider-80X data acquisition front-ends simultaneously.) Either way, the data recording path does not involve the system's Ethernet connection. This provides robust recording while preserving network communication bandwidth.

The Spider-NAS (Network Attached Storage) is a dedicated storage device that works with front-end modules from Crystal Instruments, including the Spider-80X, Spider-80SG, Spider-81, and Spider-DAQ. Eight dedicated high-speed data

buses interface directly with each Spider front-end. Each Spider-NAS dedicated data port communicates at speeds up to 480 MB/second. The Spider-NAS can store simultaneous data from all (64 maximum) attached dynamic measurement channels at a sample rate as high as 102.4 kHz, or as low as a few samples per second. An Ethernet port is used to configure and control the Spider-NAS.

### Remote Operation on Recorded Data

The recorded data can be remotely accessed and downloaded to an authorized PC anywhere in the world. This feature is particularly useful for remote machine monitoring or structure health monitoring. Multiple Spider front-ends can be installed throughout a processing factory or at a single machine location. The vibration signals and their extracted characteristic values can be recorded continuously.

| Typical Data Storage on the Spider-NAS     |  |
|--|--|
| General Functions                          | <ul style="list-style-type: none"> <li>■ NTFS file system: Supports single large data file (2 TB max)</li> <li>■ Data format: ASAM ODS data format</li> <li>■ Data samples are in 32-bit single precision floating point</li> <li>■ Data file access: EDM, FTP, removable disk</li> <li>■ Configuration Tool: EDM software from Crystal Instruments</li> </ul> |
| Storage Speed                              | <ul style="list-style-type: none"> <li>■ Up to 64 channels, each sampled at up to 102.4 kHz sampling rate retained with 32-bit floating point format (per IEEE 754-2008)</li> <li>■ Aggregate speed is greater than 26 MB/second</li> </ul>  |
| Typical Storage Duration for a 250 GB Disk | <ul style="list-style-type: none"> <li>■ 4 channel at 1 kHz/ch sampling rate: 4660 hours</li> <li>■ 8 channel at 5 kHz/ch sampling rate: 466 hours</li> <li>■ 8 channel at 102.4 kHz/ch sampling rate: 23 hours</li> <li>■ 64 channel at 102.4 kHz/ch sampling rate: 3 hours</li> </ul>  |
| Management                                 | <ul style="list-style-type: none"> <li>■ Wake-on LAN, Keyboard Power-on, Timer Power-on</li> <li>■ System power management, AC power failure recovery</li> <li>■ Watch Dog Timer</li> </ul>  |



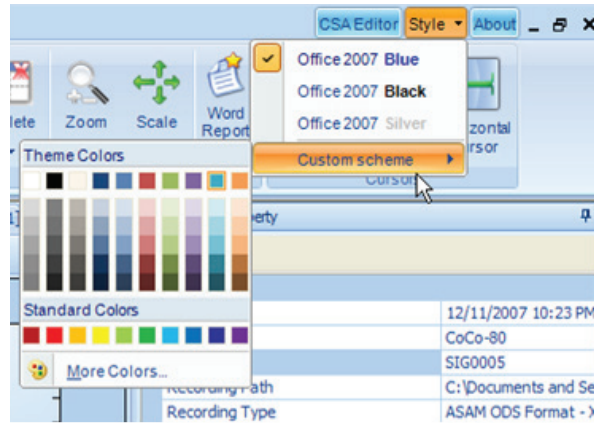

**Customizable Styles:** EDM is built completely upon the Microsoft.NET technology. The user interface has a modern look and is customizable per individual preferences.

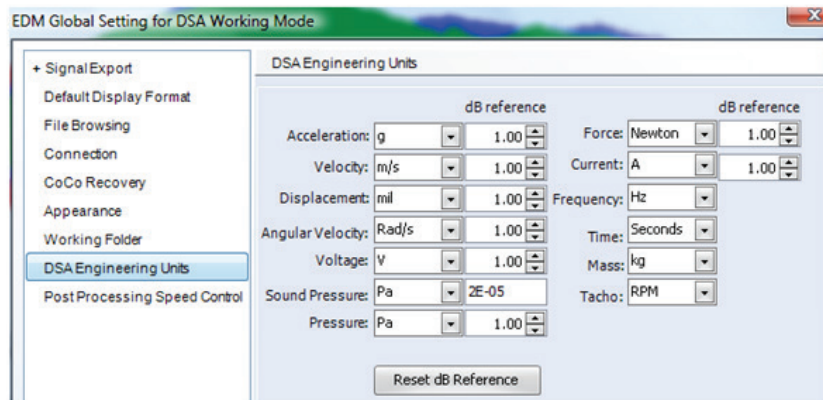

**Customizable Engineering Units:** Since the data model is built on ASAM-ODS, signal engineering units are carefully handled. The user displays the signals with user selectable quantity and units.

### User Interface

EDM is a computer software tool that is used to manage one or more CoCo-80 devices connected to the PC. The physical connection is made through either USB or Ethernet. The EDM software intelligently searches through the connected hardware devices and browses into the remote device to look at its hardware property or software files. Data files are downloaded by drag-and-drop. The user is able to download multiple files and to view the files simultaneously.

EDM is also used as a terminal to configure the CoCo devices. Project files are uploaded with one mouse click.

### Post Processing

EDM Post Processing includes a convenient tool to browse through raw data files and make selections for additional post processing. The selected time data is then analyzed using the CSA technique where the process is created using graphic functional elements designed for filtering, spectral analysis, and time-frequency analysis.

### Data File Browsing and Selection

A unique algorithm is developed to help users quickly browse through any segment of raw data files even when the files include gigabytes of data.



## EDM Modal

### Complete Modal Testing & Analysis Suite

Engineering Data Management (EDM) is a PC-based software program designed for real-time data management and processing. This easy to use, Windows-native software manages the communication between the PC and all Crystal Instruments hardware platforms.

EDM Modal is a complete Modal Testing and Modal Analysis suite for Experimental Modal Analysis (EMA). EDM Modal was developed based upon the sophisticated technologies of modern modal analysis theory and technique. With its intuitive controls and powerful features, EDM Modal is the ultimate tool for modal analysis applications. An intuitive interface allows users to manage highly complicated tests that can involve hundreds of measurement points and multiple excitations. This interface also allows for simple tests to be conducted quickly

and with little effort. Regardless of how complicated the modal test is, EDM Modal provides exactly the right tools to achieve your goal.

To successfully acquire testing data, it is essential to properly book-keep the Degree-of-Freedoms (DOFs) of the test structure. The Geometry Editor handles all types of structure modeling and supports all types of coordinate systems. Using the concept of 'components', parts of a complicated structure can be built simply and then integrated into the geometric model. Inside the Input Channel Setup window, the measurement points and their corresponding directions can be defined. Once the test is started, the measurements will proceed through all the test points, as defined by the Degree of Freedom (DOF) information for each measurement point.



## Shaker Excitation

Measuring a column of FRF matrix with one fixed excitation

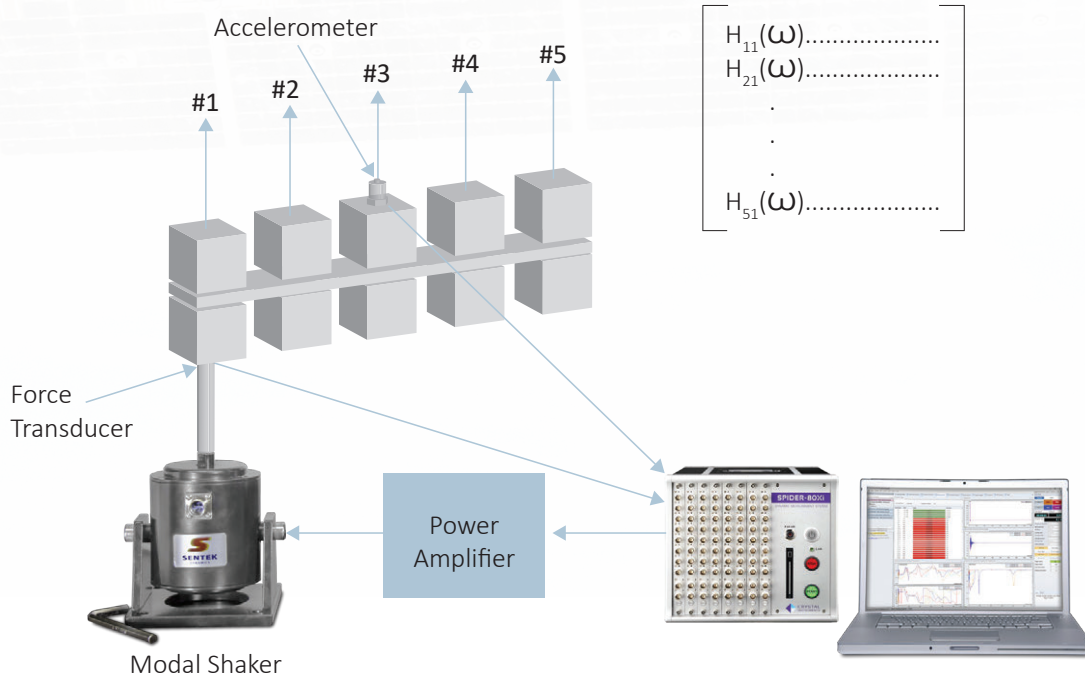

Modal parameter identification is at the heart of modal analysis. EDM Modal employs several curve fitting methods for modal parameter identification. The Least-Squares Complex Exponential (LSCE) method is implemented for the pole (natural frequency and damping factor) identification of single-reference Frequency Response Function (FRF) cases. For multiple-reference (Multiple Input/ Multiple Output or MIMO) testing cases, the corresponding Poly-Reference Time Domain (PTD) method can be used. With the knowledge of the Modal Participation Factor (MPF) from multiple reference FRF data, closely-coupled modes can be isolated. For mode shape calculation, the renowned Poly-Reference Frequency Domain method (PFD) is used, which is very intuitive.

The animation tool is a powerful visualization facility that simulates the mode shapes of the device under test, allowing users to study and understand large amounts of data through a 3-dimensional animated display. The animation module can apply color contours to the surfaces of the geometry model

to help visualize deflections in a 3-dimensional space. Free-form Deformation (FFD) enhances the mode shape animation, resulting in smoother and more realistic mode shape displays. Using the same geometry model, Operational Deflection Shapes (ODS) can be displayed using measured time or spectrum operating responses.

EDM Modal supports the following applications:

- Geometry creation/import/export/animation
- Operational Deflection Shape analysis
- Impact hammer modal testing
- Single or multiple shaker modal testing
- Single reference modal analysis
- Poly-reference modal analysis
- Reporting to Microsoft Word

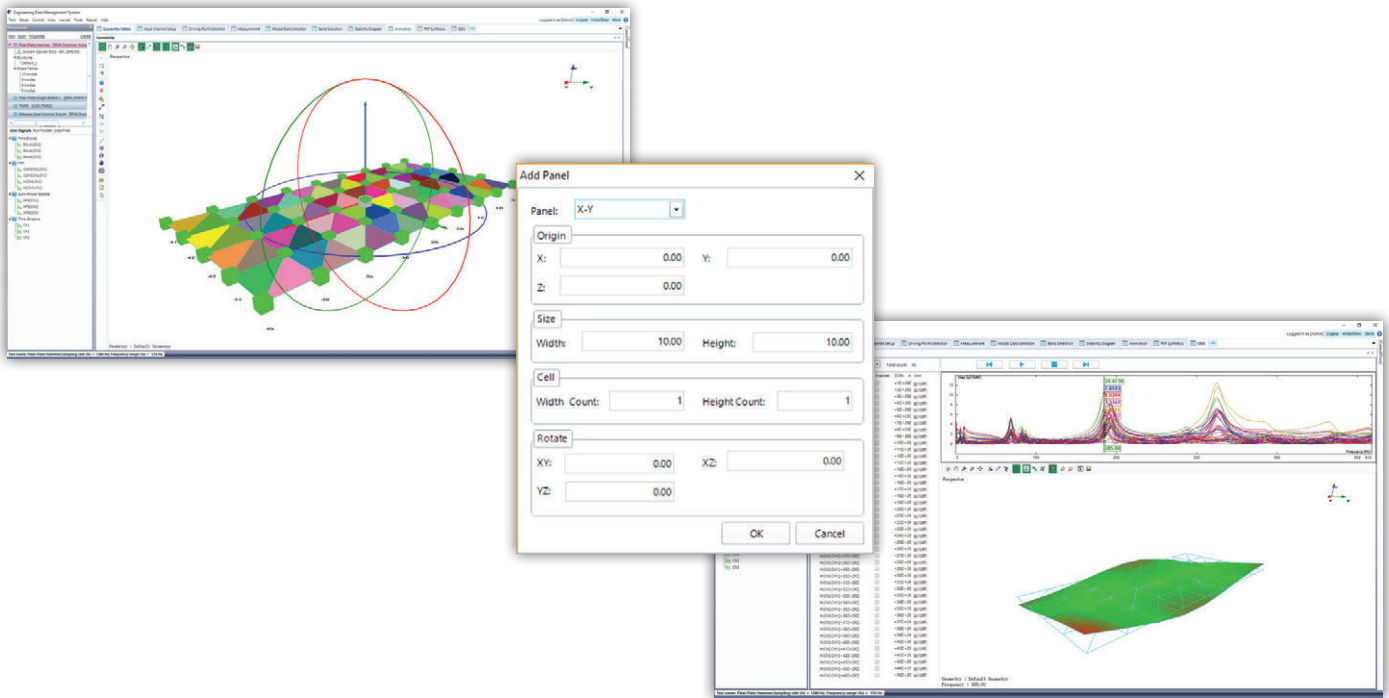

## EDM Modal Geometry

Geometry/ODS/Animation is the primary EDM Modal software module, required for every EDM Modal system. This option provides fast and efficient structural model generation and full 3D visualization of test and analysis results.

The base elements (points, lines, and surfaces) can be added/deleted graphically, or through Model Editor. The basic component library includes: line, plane, cube, cylinder and sphere. The geometry model can be saved and later recalled by other tests. The Universal File Format (UFF) format of point and line models is widely used, and may be imported to EDM Modal Geometry.

Mode shape animation can be performed using the geometry model. One cycle of the mode's animation can be saved to an .avi file.

Features:

- Basic elements: point, line, surface; editing graphically or through editor table entry
- Coordinate system: Cartesian, Cylindrical, Spherical
- Component entry: origin, direction
- Built in component library: line, plane, cube, cylinder and sphere
- Geometry model save/open/clear
- Geometry model import: UFF, CAD
- Geometry model display: point, line, surface; point directions, point number; surface norm
- Mode Shape Animation: wireframe, surface contour, FFD
- Animation speed control (fast, slow), magnitude control (increase, decrease)
- Modal Shape video saving, graph saving

## Operational Deflection Shape

EDM Modal Operational Deflection Shape (ODS) allows users to visualize the deformation of the structure under test. Time domain and spectrum data can be animated using the geometry model. It works for all types of EDM Modal testing. The database structure of EDM makes it very easy to navigate and select source data. The vibration pattern, either in time domain or frequency domain, can be saved to .avi video files.

Features:

- Data management of time domain and frequency domain
- Animation of 3D geometry model with frame or contour
- Animation amplitude control
- Animation video file saving





## Hammer Impact Testing

EDM Modal Hammer Impact Testing provides the necessary features for a single-operator experimental modal test. The Hammer Impact GUI features an intuitive step-by-step process, allowing a user to easily go through the setup and then the testing.

The testing process is designed to help users quickly define acquisition parameters. Users can define trigger behavior; preview the triggered signals. Either 'Manual-Arm', or 'Auto-Arm' trigger mode can be used.

Driving Point Selection helps users decide where to place the fixed excitation or response reference. The process is to survey several candidate driving-points, measure their FRFs. The FRF at the trial driving-point which excites most of modes can be selected as the driving-point.

When taking measurements, the status of the DOFs are indicated in a table window. The Trigger Preview window is optimized, featuring a resizable window and adjustable font size. With this added flexibility of the trigger window, users can be far removed from their display and still be able to take measurements.

EDM Modal Hammer Impact software supports automatic

detection of double hit, and give the user choice to automatically or manually reject the double strike.

Hammer impact testing is seamlessly integrated with the necessary post modal analysis inside the EDM software.

Features:

- Intuitive testing process
- Geometry based testing process
- Roving hammer or response
- Auto or manual Point/Direction increment
- Manual/Auto trigger arming
- Resizable preview window for DOFs, frame counts, impact/response waveforms
- Double hit detection on/off, auto/manual reject
- Driving point selection
- Audio/graphic feedback of test status
- H1, H2, H3, and Hv estimation
- Acquired, in progress, not acquired list of table for all DOFs

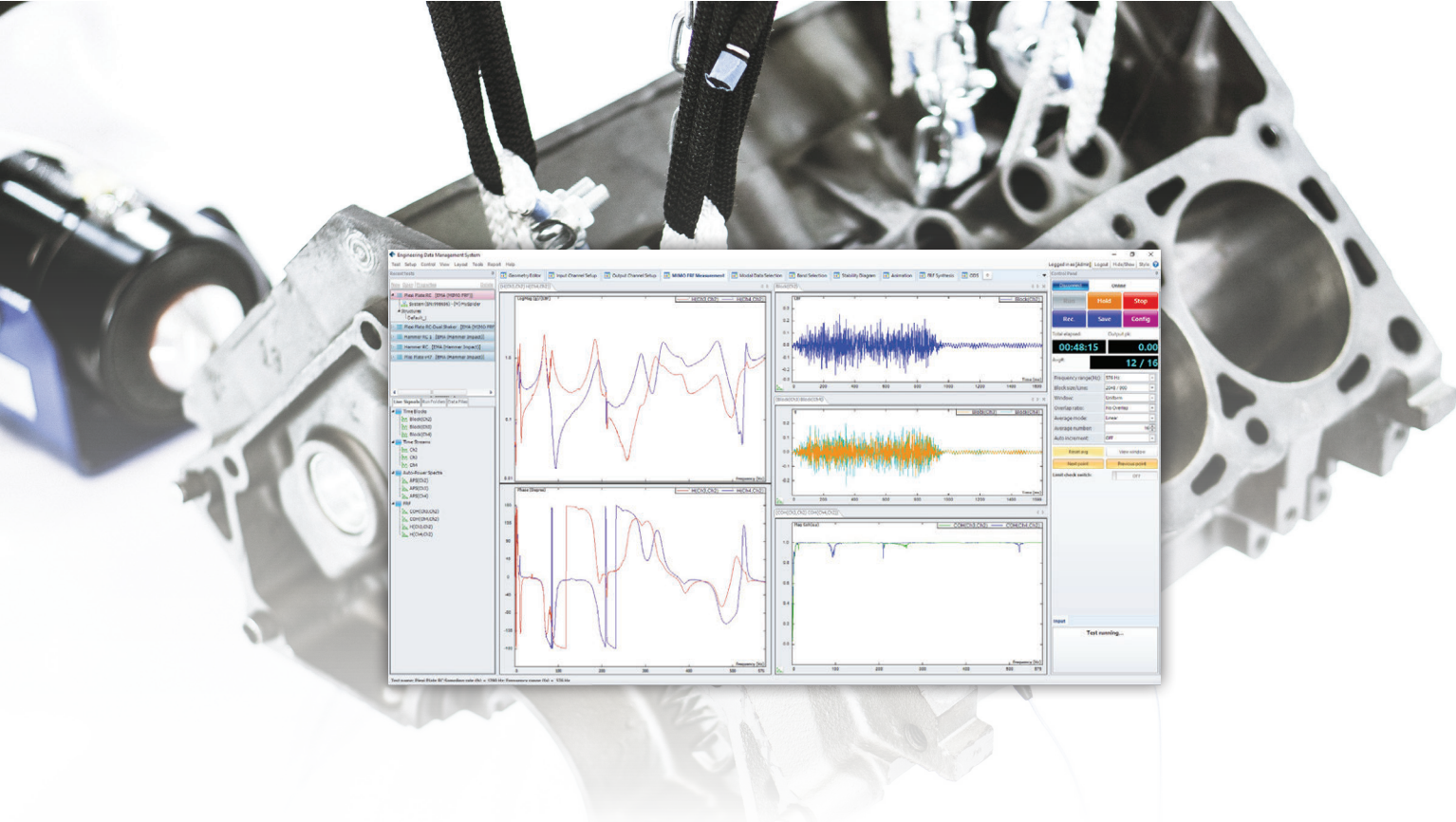

### SIMO FRF Testing

EDM Modal SIMO FRF Testing includes a dedicated test setup and operation process flow using a single shaker to acquire FRF signals. Using a large channel count data acquisition system (i.e., Spider- 80X or Spider-80Xi), this shaker excitation method provides much higher test execution efficiency for the FRF measurements.

The output type supports pure random (white noise), burst random, Chirp/Burst Chirp, pseudo random, and periodic random. For pseudo random and periodical random types, delay block and cyclic block numbers can be set bringing the structure to periodic response prior to data acquisition and cyclic average. This results in leakage-free measurements and requires no window function.

Features:

- Ease of use testing process
- Point/direction auto/manual increment
- One excitation (reference)
- Source trigger mode for synchronized acquisition and source excitation
- Random, burst random, pseudo random, period random, chirp/burst chirp output types
- Delay block and cyclic block number setting for pseudo/periodic random
- H1, H2, H3, and Hv estimation

### MIMO FRF Testing

EDM Modal MIMO FRF Testing includes a dedicated test setup and operation process flow using multiple simultaneous shakers. Using a large channel count data acquisition system (i.e., Spider- 80X or Spider-80Xi), it provides much higher efficiency and accuracy for the FRF measurements.

When using multiple shaker random excitation applications, the shaker-driving source signals are guaranteed to be uncorrelated with one another.

Multiple shaker excitation is useful to separate and identify repeated or highly coupled modes. With more than one

reference, multiple columns of the FRF signals can be measured simultaneously. Combined with the poly reference curve fitting algorithm, the modal participation factor helps to isolate the repeated and highly coupled modes. The modal analysis process is seamlessly integrated with the MIMO FRF testing.

Features:

- Includes all features of SIMO FRF test, plus,
- One or multiple excitation (reference)

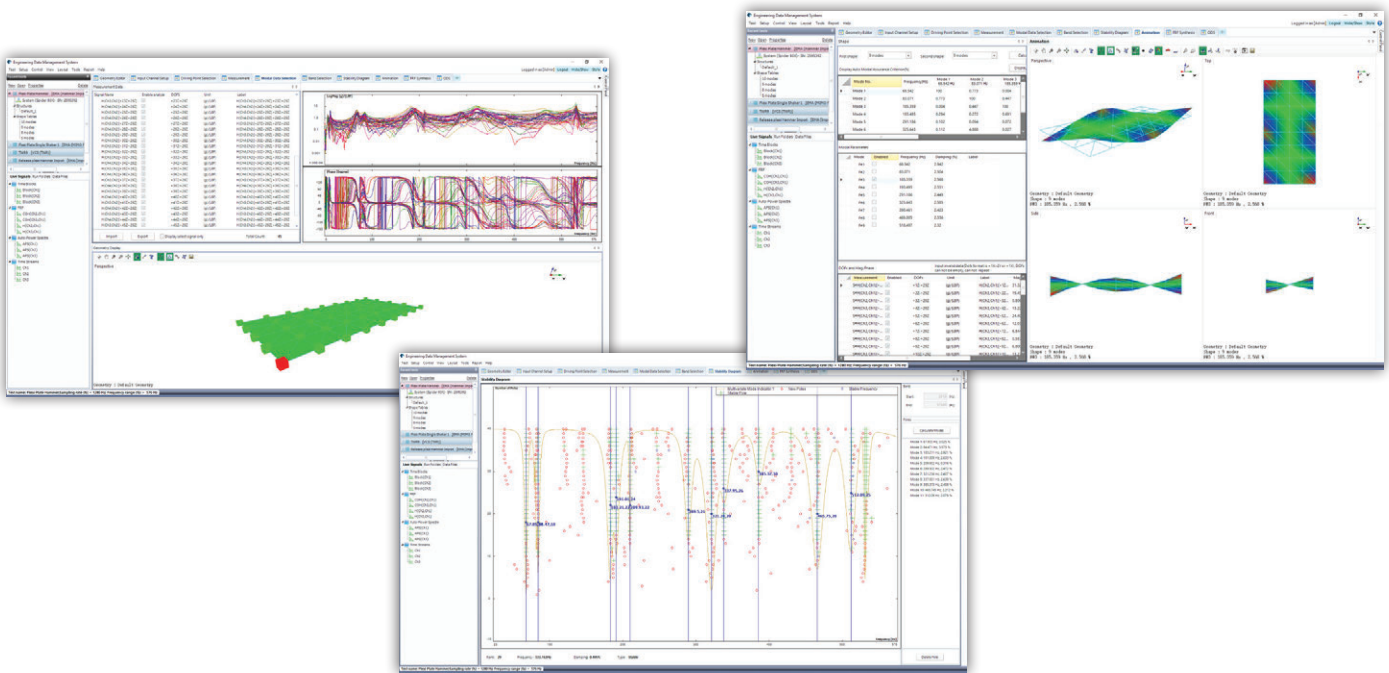

## Standard Modal Analysis

EDM Modal Standard Modal Analysis provides a complete arsenal of tools, from FRF data selection, parameter identification, to mode shape animation and results validation.

Upon completion of the modal testing, the set of FRF data is available for modal analysis. Individual FRF signal can be added/replaced. The complete set of FRF can be exported, or imported from other sources. These operations are managed by 'Modal Data Selection'.

Available Mode Indicator Function (MIF) are Multivariate, Complex, Real, and Imaginary Sum. A Stability Diagram is employed for modal parameter identification, using proven Least Square Complex Exponential (LSCE) fitter for pole identification. The stable poles can be selected from the Stability Diagram for the mode shape calculation, using the Least Square Frequency Domain (LSFD) algorithm.

The resulting mode shape table can be saved and used for mode shape animation. Modal Assurance Criterion (MAC) function and FRF synthesis are also available, providing means for modal parameter validation.

Features:

- Ease of use modal data selection
- MIF: Multivariate MIF, Complex MIF, Real MIF, Imag sum MIF
- User selectable frequency band for parameter identification
- Stability Diagram
- Curve fitting method: LSCE
- Mode shape: LSFD
- Save/append modes to the shape table
- Mode shape animation
- Mode shape animation save to video file
- Auto/Cross MAC calculation and display
- Synthesized FRF vs. measured FRF
- Import/export modes: UFF format

## Advanced Modal Analysis

EDM Modal Advance Modal Analysis includes all the features of Standard Modal Analysis. On top, it provides the Poly-reference modal analysis algorithm to curve fit the FRF matrix from the MIMO FRF testing results. The time domain curve fitting algorithm for the pole identification is Poly reference time domain method (PTD), which is sophisticated and proven.

The selection of the curve fitting method, PTD or LSCE, is

automatic based on the type of FRF signal set selected, whether it is single reference or multi reference.

Features:

- Includes all features of Standard Modal Analysis, plus,
- Poly reference time domain (PTD) curve fitting



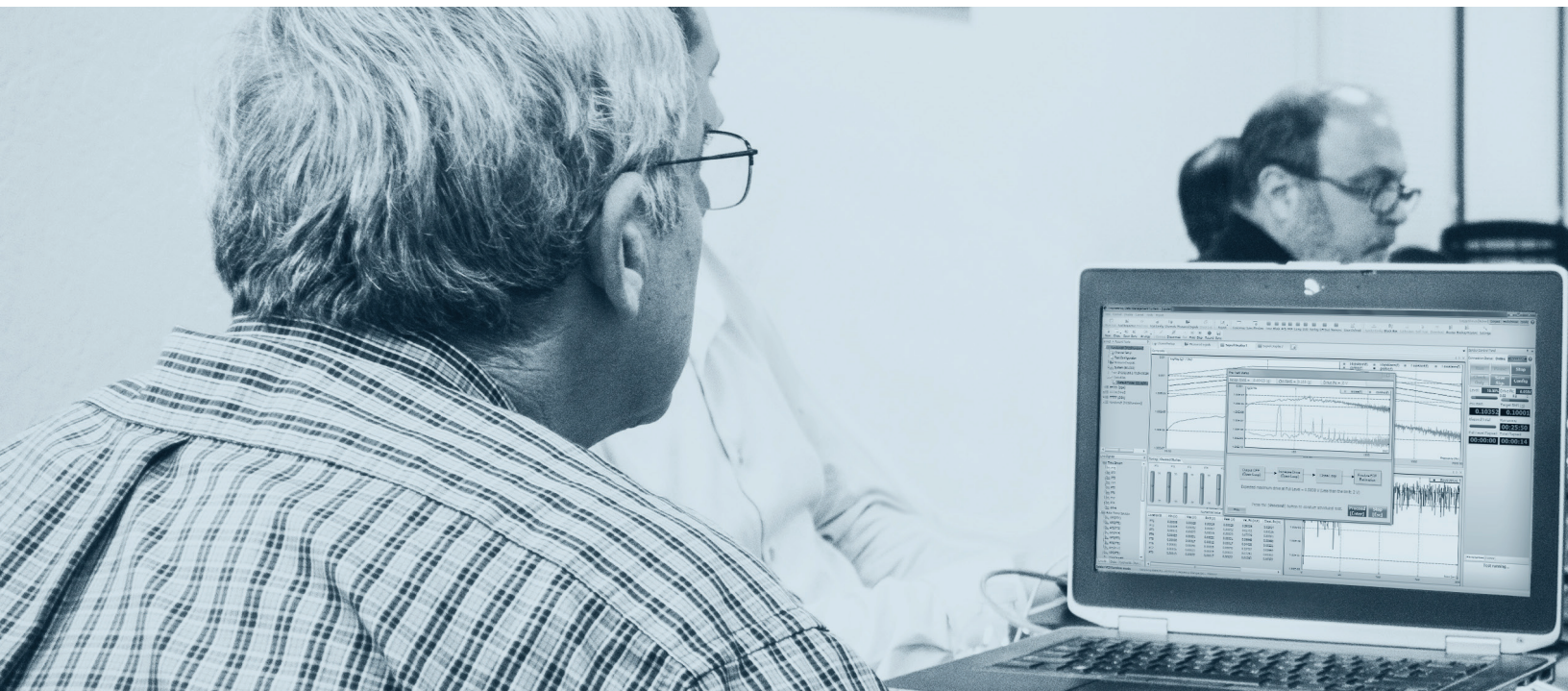

## EDM Post Analyzer Software

Crystal Instruments offers EDM Post Analyzer software, a powerful adjunct to your Spider-based analysis tool kit, allowing you to analyze Time Stream recordings made using your Dynamic Signal Analyzer. The beauty of this approach is that it lets you analyze and reanalyze digitally recorded data after the recording event.

Recording first and analyzing second makes great sense to first-responding problem solvers. Simply recording does not require all of the tactical measurement decisions be made before data is taken. Often a new problem requires some “get acquainted” measurements to really define the difficulty and its root cause. We are often not smart enough to guess what causes our new challenge. We need to look at some representative measurements from different analytic viewpoints to begin to understand the problem and home in on its solution. The approach is eminently suitable for a team effort. A recording technician can acquire data using minimum equipment while the analyst can remain on post with his analytic workstation.

To offer a complete package of both real-time analysis and post processing, Crystal Instruments developed three separate but

related software modules: Post Analyzer, Waveform Editor, and File Converter. Post Analyzer (PA) contains many powerful post processing tools with batch processing capability. Post Analyzer is an independent Windows application that analyzes recorded data files on a computer using various algorithms. Most of the algorithms implemented in PA are identical to those used in the real-time DSP of the Spider hardware. The user should expect the same or very similar calculation results using PA to those computed in the hardware in real-time. This document describes the PA functions.

Waveform Editor is an independent Windows application that allows the user to cut, edit or merge the time waveforms. File Converter is an independent Windows application that converts files in various data formats to standard ATFX format.

For convenience of ordering, we also created three bundles of PA: PA Viewer allows the user to view data and create reports; PA Basic has FFT spectral analysis, curve fitting, demodulation spectrum and 3D signal display functions; PA Premium has more advanced functions including Waveform Editor, File Converter, offline sine reduction, real-time filters, octave filters and order tracking.

Engineering Data Management (EDM) is a complete suite of turn-key solutions for both real-time processing and post analysis. Shown below are typical screen shots of EDM PA functions, in the following order: Post Processing, PA Spectra, and PA Projects.

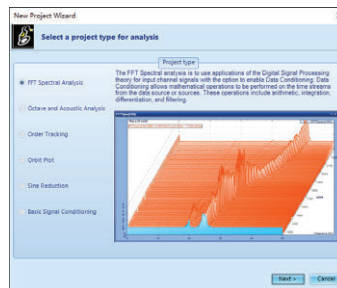
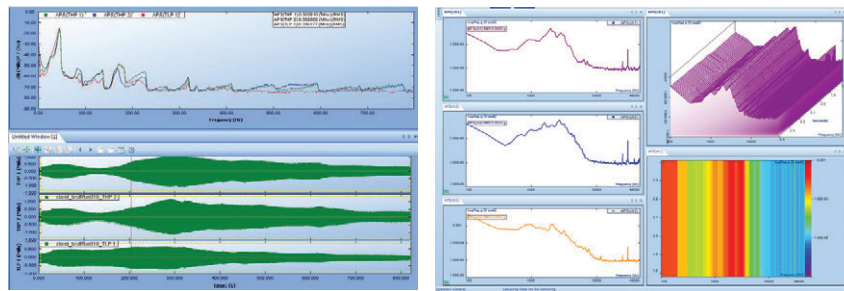

| Function   | PA Viewer | PA Basic | PA Premium |
|--|-----------|----------|------------|
| Browse, display, and edit long waveform files  | √         | √        | √          |
| Signal display with different spectrum unit and X-Y scale  | √         | √        | √          |
| Signal annotation, cursor, play sound, calculate RMS, THD, ZOOM-in, ZOOM-out, auto scaling                           | √         | √        | √          |
| Create template-based report in HTML, Excel, Word or PDF   | √         | √        | √          |
| Engineering unit conversion, dB reference  | √         | √        | √          |
| Export to standard formats including ASAM-ODS, UFF, BUFF, MATLAB, user-defined ASCII, and wave files                 | √         | √        | √          |
| 3D display: waterfall, colormap  | √         | √        | √          |
| Import user-defined ASCII file, wave file, Pacific Instrument file   |           | √        | √          |
| Acceleration, velocity and displacement conversion   |           | √        | √          |
| Polynomial Curve Fit   |           | √        | √          |
| FFT Spectral analysis: FFT, auto power spectra, cross power spectra, frequency response function                     |           | √        | √          |
| Math Functions: abs, +, -, *, /, square, square root, log, integration, differentiation, RMS, peak, offset and scale |           | √        | √          |
| User defined data conditioning modules (PA-05)   |           |          | √          |
| Digital Filters: IIR, FIR, Low-pass, High-pass, Band-pass (PA-06)  |           |          | √          |
| Shock Response Spectra (SRS) (PA-07)   |           |          | √          |
| Fractional octave filters and SLM: 1/1, 1/3, 1/6, 1/12 (PA-08)   |           |          | √          |
| Order Tracking: RPM spectra, order spectra (PA-09)   |           |          | √          |
| Offline Sine Data Reduction (PA-10)  |           |          | √          |

## EDM Post Analyzer Ordering Information

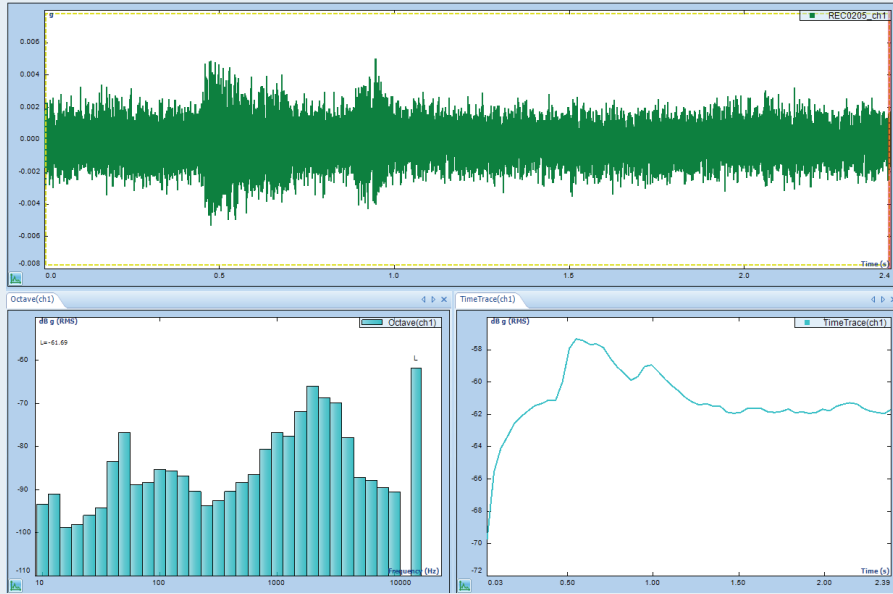

### EDM - PA Software

| Part Number | Description                                    |
|-------------|--|
| PA-05       | User Defined Signal Conditioning               |
| PA-06       | Digital Filters and Resampling                 |
| PA-07       | Shock Response Spectrum                        |
| PA-08       | Octave Analysis and SLM Analysis               |
| PA-09       | Order Tracking and Rotating Machinery Analysis |
| PA-10       | Offline Sine Data Reduction                    |

### EDM - PA Bundles

| Part Number | Description  |
|-------------|--|
| EDM-01      | PA Viewer: View data, export data to UFF, BUFF, MATLAB, user-defined ASCII, and wave files. Generate reports. Option is included with all CoCo or Spider purchases. Includes File Converter and Waveform Editor. |
| EDM-02      | PA Basic bundle: In addition to functions of PA Viewer, PA Basic includes 3D display, File import, File export, trigger, FFT post-analysis.  |
| EDM-03      | PA Premium bundle: In addition to PA Basic, PA Premium includes signal conditioning, digital filter and resampling, SRS, octave analysis and SLM, order tracking, offline sine reduction.                        |



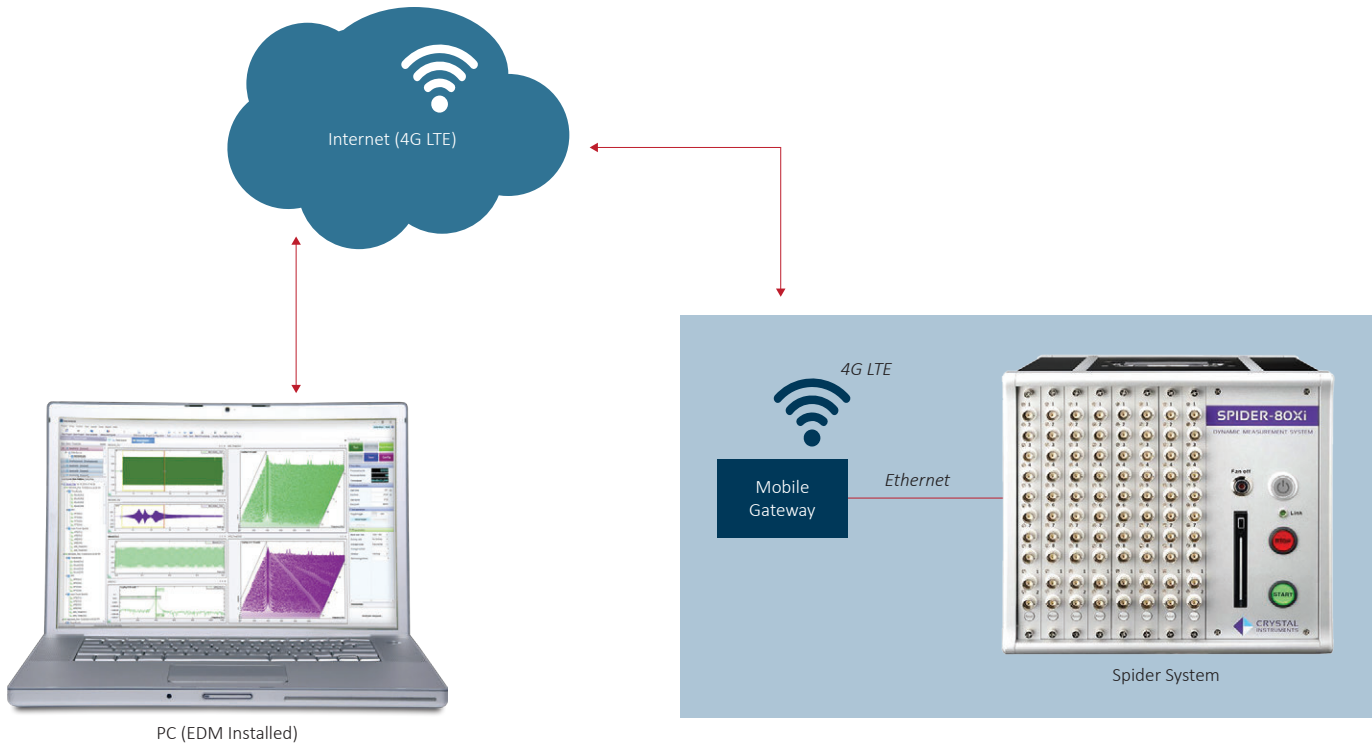

## Wireless Remote Condition Monitoring Hardware and Software Solutions

Sometimes a test conducted at a proving ground in Michigan needs to be controlled by engineer in California or a wind turbine in Germany requires observation by designers in Japan. That's when wireless remote monitoring is the tool of choice and wireless service providers have expanded rapidly to support worldwide connectivity.

In the United States, cellular carriers such as Verizon, AT&T and Sprint have covered the most populated areas of the country with 4G LTE technology and the transmission bandwidth can easily reach to 10 to 20Mb/s. Other developed countries have wireless networks that reach and surpass that of the United States' and even developing countries are rapidly expanding wireless internet connectivity.

A Crystal Instruments Spider system connected to a Mobile Gateway modem can be wirelessly linked to a PC in an office which is running EDM (Engineering Data Management Software). This means that a Spider system placed in a moving car can be remotely monitored and controlled by a PC with an internet connection running EDM software. The Mobile Gateway modem makes the remote in-vehicle operation of Spider system possible. Crystal Instruments has developed

several competitive features that help its line of Spiders succeed at wireless remote condition monitoring.

The hardware and software of the Spider system are designed so that the network control terminal (comprised of EDM and the PC) is not in the critical control loop. If the connection fails or slows due to limitations in the transmission, such as the wireless connection becoming bad, neither the data acquisition nor the monitoring functions on the Spider system will be interrupted. The Spider would default into "Black Box mode" which is a self-sufficient system. The design function resilience of the Spider system assures that no external failures will compromise its smooth operation.

Power consumption is a big concern for remote monitoring and the Spider excels in this area. A Spider has an internal flash memory that stores all the software code, configuration parameters and the measurement data. This design runs the system at a low power consumption. A typical Spider-80X unit, which can acquire data at 102.4 kHz with 8 inputs will only consume about 10 watts of power and a four input Spider-20E only consumes about 6 watts.

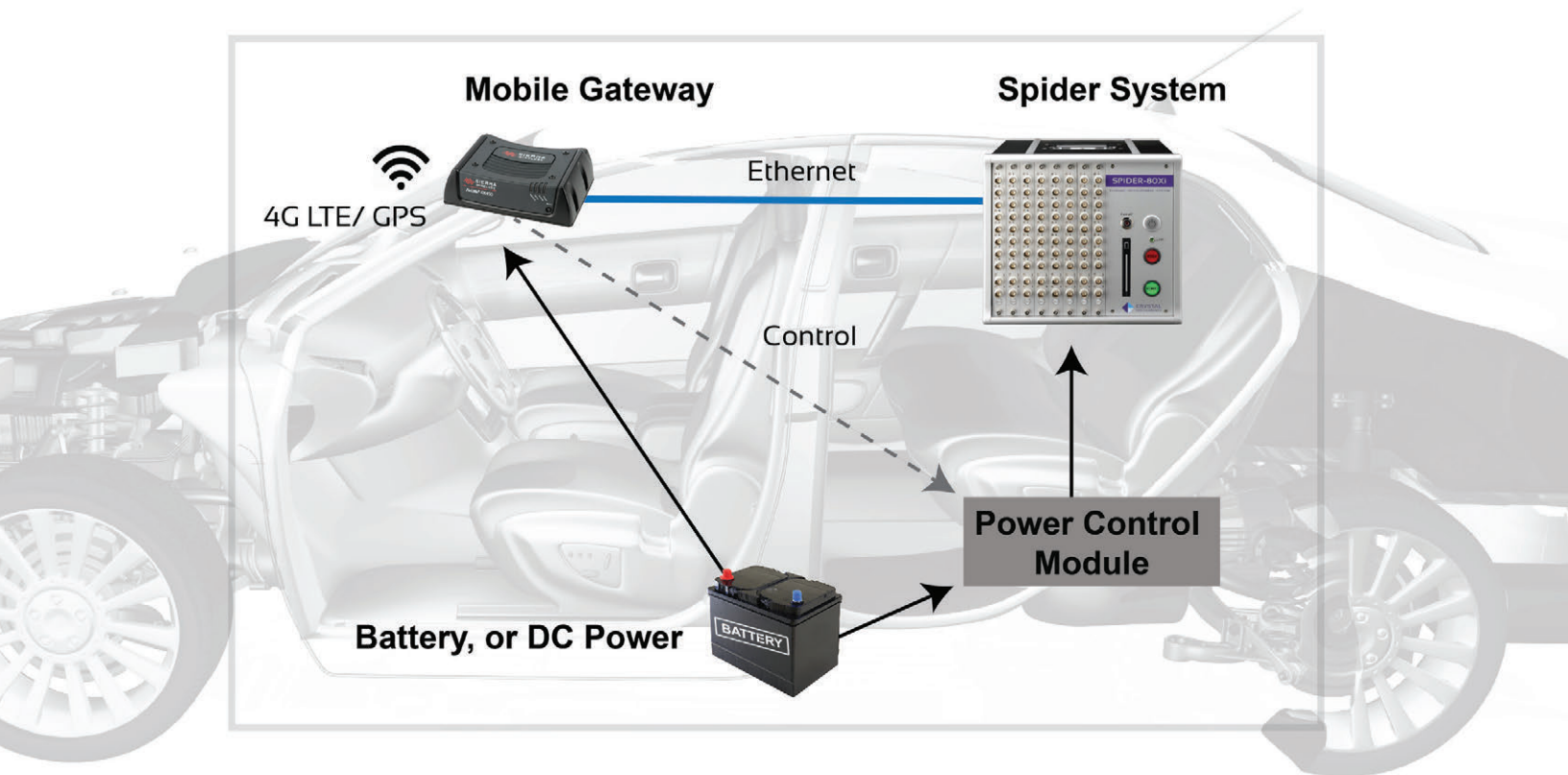

**Wireless Remote Monitoring Features**

- Low Power Consumption
- 150 dbFS Dynamic Range
- “Black Box” Mode (No PC Required)
- Reliable in All Circumstances

Another advantage of the Spider system is its independence of a PC in a remote area. All of its input channels use patented dual A/D technology that can achieve more than 150 dBFS dynamic range, completely eliminating the input gain setting.

Signals as low as a few microvolts or as high as 20 Volts can all be accurately measured without human attention to their amplitude. This unique feature is especially beneficial when the measurement is taken remotely without attendants. Applications could include a test performed on a train traveling long distances over a railroad, a test performed high in a wind turbine, or a test of a vehicle conducted by a professional driver.

Reliability, low power consumption, “Black Box mode,” and a very high dynamic range make the Spider system uniquely capable of wireless remote condition monitoring.

**Providing Power to the Spider and Wireless Gateway Modem**

The active power consumption of one eight-channel Spider module is less than 10 watts. The power consumption of wireless gateway modem is 1 watt or less. The modem also has an idle mode that consumes much less power. It is feasible to use battery power, or solar assisted power source to power the units.

Crystal Instruments developed an intelligent power control module that can shut down and power on the Spider system through the modem.

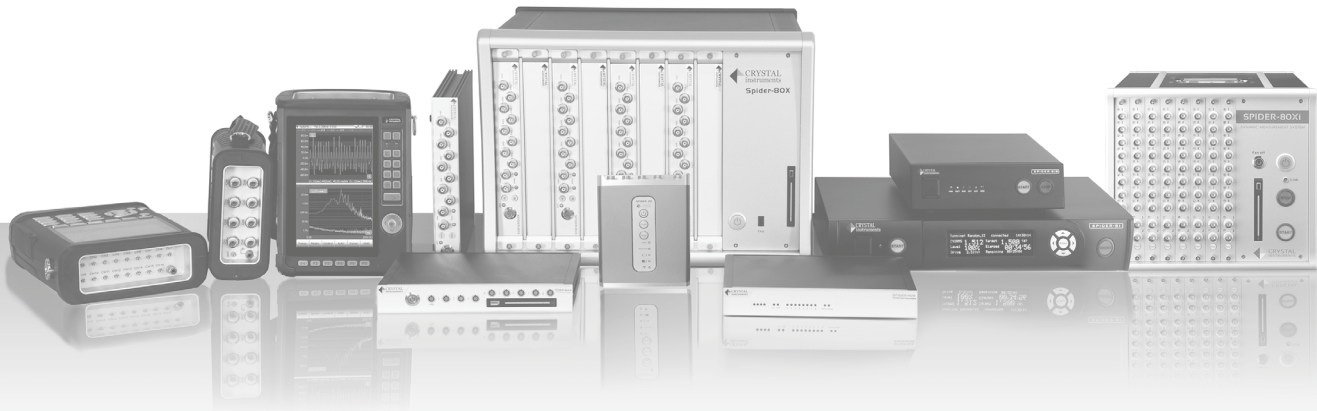

## Premier Technology Support Agreement

Crystal Instruments understands the enormous investment our clients put into our products. We match their investment by offering the most comprehensive technical support agreement in the industry. From support calls to staff training, Crystal Instruments provides solutions to our customers' needs.

The "Premier Technology Support Agreement" offered by Crystal Instruments is fairly priced as a small percentage of the total purchase value. The services offered and included in the agreement are for the duration of 1 year. The agreement is renewable at a locked in rate as a subscription. Rates are subject to increase if a subscription is not continued at the time of renewal and signed up for at a later time. Please contact Crystal Instruments for pricing information.

Services offered are:

- Annual software upgrade program - accessible by convenient online downloads
- Annual hardware calibration
- Priority phone/email/live video support from highly trained engineers
- Temporary replacement unit for hardware in 48 hours
- Data recovering services
- Hardware repair when the total service hours required is less than 4 hours per incident

### Annual Hardware Calibration

Crystal Instruments DMS is certified by ISO:9001. Hardware calibrations are also performed at the customer's site upon request. Customers with a Premier Technology Service Agreement will receive standard annual hardware calibration services at no additional cost (a \$1500 value).

### Annual Software Upgrades

Crystal Instruments provides convenient solutions for software upgrades. Users are able to download the latest versions of Crystal Instruments' Engineering Data Management (EDM) software through the support website.

Other options include emailed links to download software updates, physical CD-ROMs sent to your location, and installation instructions provided over the phone by our highly qualified Applications Engineers. Customers with a Premier Technology Service Agreement will receive standard software update services at no additional cost.

### Temporary Replacement Units

Crystal Instruments strives to minimize any inconvenience to our customers' operations. Temporary replacement units are often provided to customers as a solution. Units will usually be assigned to customers within 48 hours or less.

### Live Product Support

Crystal Instruments support staff is based in Santa Clara, CA at our corporate headquarters. Our support staff provides phone and email support from 8am to 5pm PST, Monday through Friday. All support is provided by highly trained engineers, not technicians. After hours support is also available upon request.

Crystal Instruments' highly diverse staff provides native language support in English, Spanish, Mandarin, Cantonese, Japanese, Taiwanese, Persian, Hindi, and Vietnamese.

### Hardware Repair Services

Crystal Instruments provides hardware repair for units estimated to have a 4 hour or less repair service period. Additional hours required for repairs are charged at an hourly rate. Replacement parts are discounted by 30% under the Premier Technology Support Agreement. All hardware repair takes place at Crystal Instruments headquarters in Santa Clara, CA. Our highly trained technicians will accurately and efficiently repair your equipment in our ISO:9001 certified facilities.

### Data Recovery Services

Crystal Instruments understands the importance of recovering any lost data safely and securely. Our staff is ready and available to assist you through any data loss crisis.



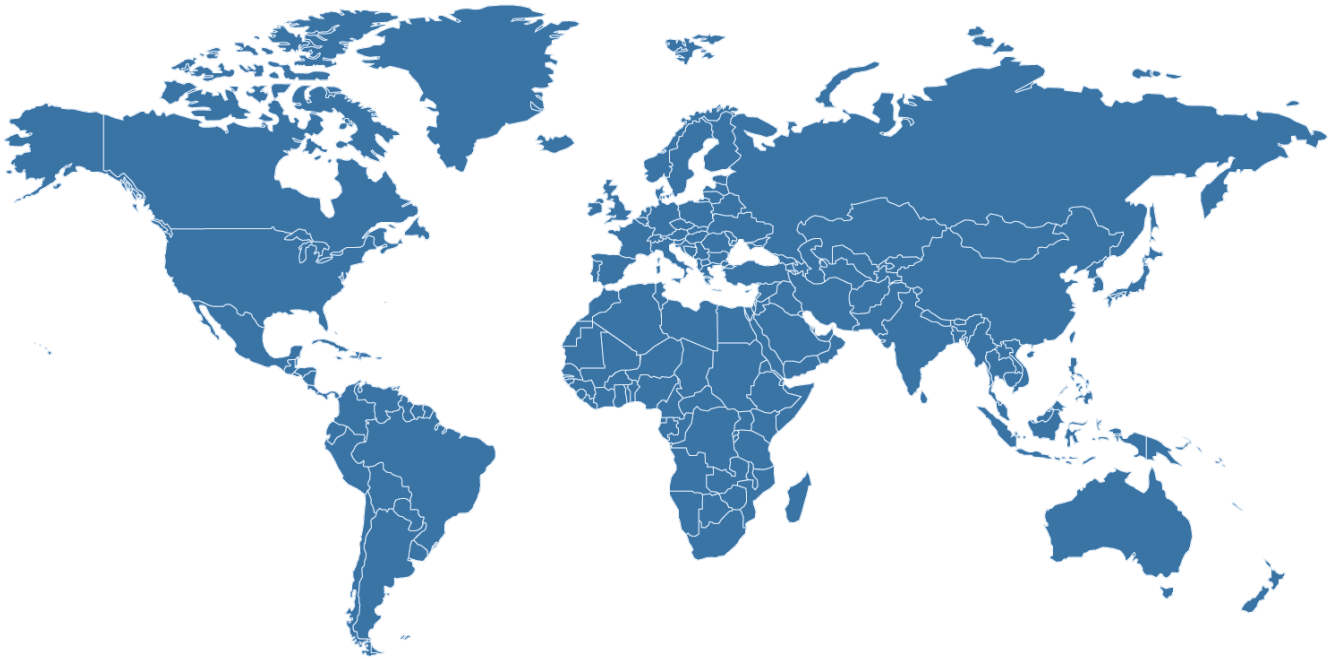

To find a distributor near you, please visit our website:

CRYSTAL INSTRUMENTS  
2370 OWEN STREET  
SANTA CLARA, CA 95054 (USA)

PHONE: +1-408-986-8880  
FAX: +1-408-834-7818

EMAIL: [INFO@GO-CI.COM](mailto:INFO@GO-CI.COM)  
[WWW.CRYSTALINSTRUMENTS.COM](http://WWW.CRYSTALINSTRUMENTS.COM)

© 2017 Crystal Instruments Corporation. All Rights Reserved. 05/2017

Notice: This document is for informational purposes only and does not set forth any warranty, expressed or implied, concerning any equipment, equipment feature, or service offered or to be offered by Crystal Instruments. Crystal Instruments reserves the right to make changes to this document at any time, without notice, and assumes no responsibility for its use. This informational document describes features that may not be currently available. Contact a Crystal Instruments sales representative for information on features and product availability.