



EDM 11.1

Engineering Data Management Software Release Notes

SPIDER VIBRATION CONTROL SYSTEMS (VCS)
MULTIPLE-INPUT MULTIPLE-OUTPUT VIBRATION CONTROL SYSTEMS (MIMO VCS)
DYNAMIC SIGNAL ANALYSIS (DSA)
POST ANALYZER (PA)
EXPERIMENTAL MODAL ANALYSIS (EMA)
TEMPERATURE, HUMIDITY, VIBRATION (THV)



TABLE OF CONTENTS

Release Highlights	4
Shutdown Protection System	4
• Shutdown protection using unfiltered data	4
• Shutdown protection using filtered data	4
• Proportional Filter	4
• Fixed Bandwidth IIR Filter	4
• Fixed Bandwidth IIR + Proportional Filter	5
Sigma Clipping is Improved by Intelligent Clipping Algorithm	5
• Improved Dynamic Range	5
• Reduction of high frequency component to the signal	6
Signal Viewer	6
• Import and Display Signals	6
• Filter Data Files	6
• Export Data Files	7
Executing OMA Using Time Stamp Technology on Multiple CoCo Devices	7
Data File Browser	8
Spider runs as Power Stabilizer System	8
New EDM CoCo Mode	8
• Control Multiple Units	9
• Batch Operations	9
• Time Stamped Signals	9
• File Viewer	10
• Encryption	10
• Arbitrary Waveform Editor	10
• Sensor Library	10
New Blade Fatigue Testing Features	10
• Configure Control Channel for Sweep and Dwell in One Place	10
• Configure Profile for Sweep and Dwell in One Place	11
• Manual Search, Automatic Search, and Adjust Dwell Parameters during test	11
• Readout for BFT	11
• Dwell Table	11
4-Shaker MIMO Random Control	11
New Features	12
New Features in EDM-VCS Vibration Control Software	12
• More User Notes in Checklist and Reports	12
• Burst Mode in ROR	12
New Features in MIMO/MESA Vibration Control Software	12
• CAN Bus support for MIMO and MESA control types	12
New Features in EDM Dynamic Signal Analysis	12
• Measure histogram, crest factor and Kurtosis	12
• Histograms:	13
• Crest Factor and Kurtosis Time histories:	13
• Spiders automatically run a test in Black Box mode after powering on	13
• Extend recording duration when multiple triggers are received, or multiple limits are exceeded.	13
• Tripartite Response Spectrum	14
• DSA - SRS Statistic Window Improved	14
New Features in Post Analyzer	15
• PA -SRS Statistic & tolerance window	15
New General Features	15
• Support 1V range on Spider-80SG/80SGi/80Gi in all EDM Applications	15
Major Improvements	15
EDM Vibration Control Software	15
• Sine Oscillator supports up to 512 channels	15
• Test Profile Tolerance editing improvement	15
• Report Builder improvements	15
• Report, Report Builder (all app modes) to read in run log (origlog) from file system:	16
• Report, When EDM generates a report, the report contents can be appended to the word file selected by a user	16

• Other Improvements	16
• Improvements in Random	17
• Improvements in SoRRoR	17
• Improvements in Shock/TTH/SRS/Earthquake Testing/Transient Random	18
• Improvements in Shock/TTH/SRS/Earthquake Testing/Transient Random	18
• Improvements in Transducer Calibration	19
EDM THV Control Software	20
• Temperature Channels can be assigned to RTD100 and Thermocouple sensors respectively	20
• 16 Additional Temperature Monitoring Channels	20
• EDM THV and EDC support Spider-101 v3	20
• Air Dryer Support	21
• Product Temperature Control	21
• Liquid Nitrogen Cooling Support (optional)	21
• Read Chamber Status with Modbus	21
• Other Improvements in EDM THV	21
Experimental Modal Analysis	21
• Enhancement of geometric modelling	21
Front-end Calibration Tool (FECT)	21
• Improved Message for Spider-80M Factory Calibration	21
• Apply calibration results to passing channels and skip those that failed	22
• Factory Calibration Supports Keithley DMM6500	22
• Factory Calibration Supports Spider-80M FECT Fixture	22
• Include 1 V Range Measurements for Spider-80SG/80SGi/80Gi	22
Signal Viewer Improvements	22
• Signal Viewer report generation should have file name and directory	22
• Generate report menu should not open if no signal files are loaded	22
• Default signal to report should be any plotted signals	23
• Signal Viewer should preload all opened signals for improved filtering performance	23
• Change text to add .origlog and .atfx extensions in Report Generation window	23
• Added a “Remove all” button next to “Remove”	23
General Improvements	23
• EDM Software supports In-line Charge Converter and External Charge Amplifier on all Spider products	23
• Rename Test	23
• Cursor / Marker window no longer automatically shows	24
• RMS box now supports copying to clipboard	24
• Spectrum Format (Global Settings) refactor	24
• Drag file to plot signal	24
• Saving Multiple Licenses	24
• Active Key Column	25
Software Release History	26
System Requirements	26
Minimum system requirements	26
Recommended system requirements (minimum for Spider systems higher than 16 channels)	26
Version Compatibility	26

RELEASE HIGHLIGHTS

Shutdown Protection System

CI Spider systems featuring a digital input and output (DIO) interface along with EDM VCS software compatibility can run as a shutdown protection system. The main purpose of this function is to act as an independent hardware system to protect the shaker system. It can send out a shutdown digital output signal in less than 10 milliseconds based on various signal trigger conditions. It also includes various tracking filters that are identically implemented in the Sine controller.

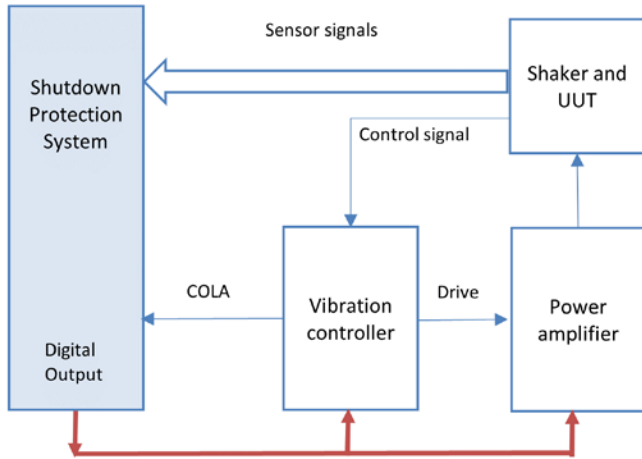

Shutdown protection using unfiltered data

Uses time data acquired from sensors to detect if a threshold is exceeded and sends a digital output signal. It is typically useful in scenarios where the harmonics of the driving frequency potentially causes the overall vibration amplitudes to exceed acceptable limits.

The **reaction time** between the first time-domain data sample exceeding the threshold to the time of sending the digital output was determined to be about 7 ms using this approach for the shutdown system.

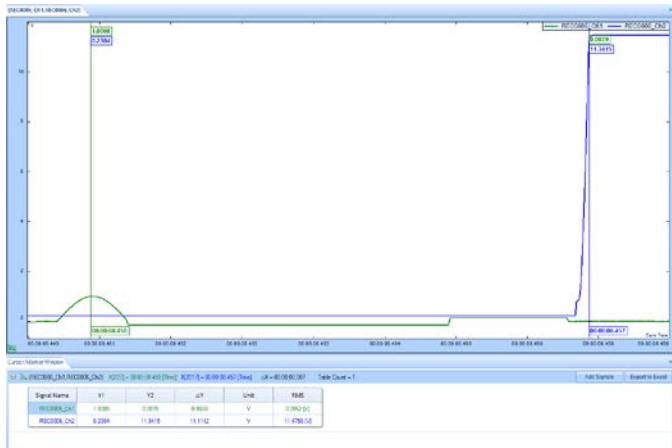

The reaction time is extremely quick and is less than 10 ms for any channel. This approach is extremely advantageous when the overall vibration or the vibration peak needs to be limited.

Shutdown protection using filtered data

For applications involving a comparison of amplitudes for only the driving frequency, a tracking filter is required to filter all other frequencies around the driving frequency.

Proportional Filter

The bandwidth of the Proportional Tracking Filter is proportional to the driving frequency. It is the fastest filter at any frequency range and has operational capabilities down to drive frequencies of 1 Hz with minimal delays.

A major advantage of the Proportional Filter is very high attenuation at harmonic frequencies. Considering that the harmonic frequencies are the most dominant frequencies during Sine vibration testing on a shaker, the Proportional Filter is the most ideal filter type to yield quick and accurate results.

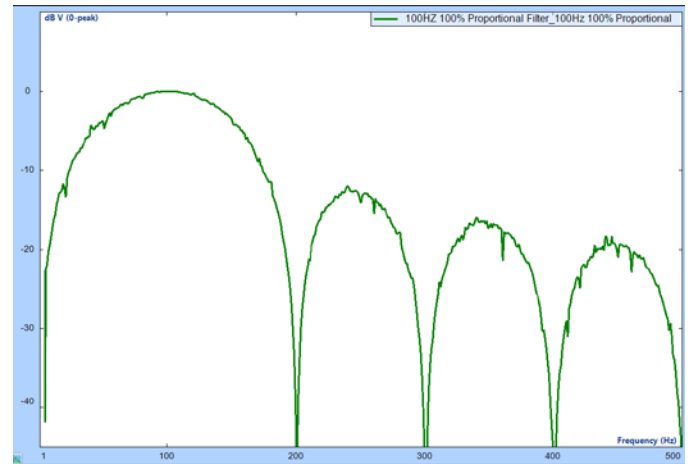

Figure 1. Frequency response of the 100% Proportional Filter with a center frequency of 100 Hz

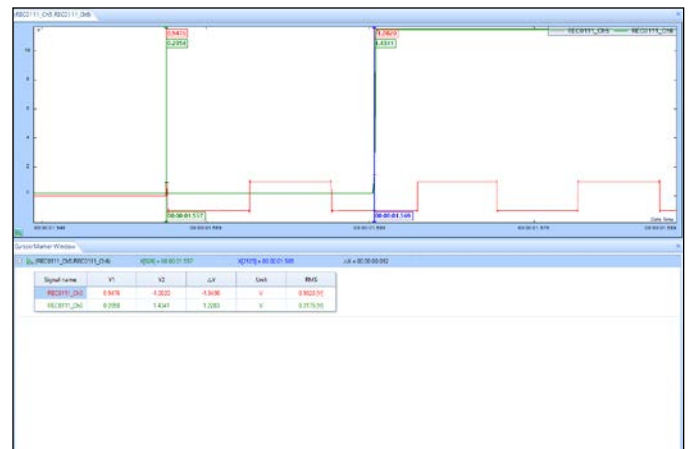

Figure 2. Time delay between when a square wave with a 100 Hz frequency exceeded a frequency-based limit (green cursor) and when the Spider-80Xi's digital output was triggered (blue cursor).

Fixed Bandwidth IIR Filter

The primary advantage of a Fixed Bandwidth IIR Filter is that the bandwidth is constant at all frequencies. If resonant frequencies of the DUT is a major concern, it is ideal to use the Fixed Band IIR Filter instead of the Proportional Filter because a smaller bandwidth at high frequencies can significantly attenuate the response due to resonant frequencies. As in the case of any IIR Filters, the reaction time is inversely proportional to the bandwidth of the filter.

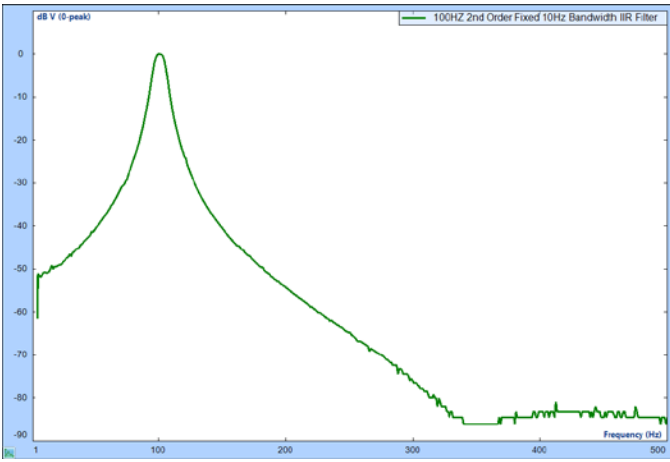

Figure 3. Frequency response of the 2nd order 10 Hz fixed bandwidth IIR Filter with a center frequency of 100 Hz

The 2nd order filter has a reaction time around 80 ms and the 4th order filter has a reaction time around 130 ms.

Fixed Bandwidth IIR + Proportional Filter

The Fixed Bandwidth + Proportional Filter is designed so that the harmonics attenuates significantly while keeping a fixed bandwidth. Thus, the filter is extremely effective even down to 1 Hz in effectively eliminating the harmonics while keeping a fixed band at high frequencies. The reaction time is within milliseconds which makes it ideal for all applications.

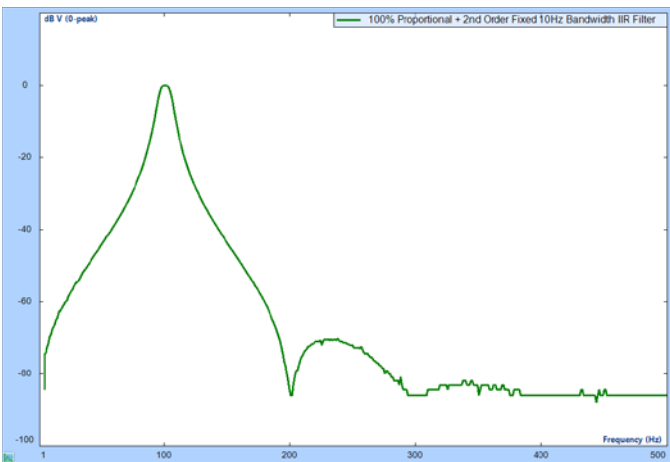

Figure 4. Frequency response of the 100% Proportional + 2nd order 10 Hz Fixed Bandwidth IIR Filter with a center frequency of 100 Hz

Users can observe that the filter preserves high attenuation at harmonic frequencies while keeping a fixed bandwidth at high frequencies.

Driving Frequency	Reaction Time
10 Hz	142 ms
20 Hz	104 ms
50 Hz	92 ms
100 Hz	86 ms

Reaction time using a 100% Proportional + 2nd order IIR 10 Hz Fixed Bandwidth Filter

The Fixed Bandwidth IIR + Proportional Filter resolves the Fixed Band IIR Filter issues by working effectively down to 1 Hz without increasing the reaction time at high frequencies.

Advantages of Fixed Bandwidth IIR + Proportional Filter

The Fixed Band IIR + Proportional Filter is ideal for any application with a sweep range down to low frequencies such as 1 Hz and a narrow passband is required at high frequencies.

If a Fixed Band IIR Filter is used, the bandwidth selection must be very small which makes the reaction time a matter of seconds. However, in the case of a Fixed Band IIR + Proportional Filter, the reaction time is very small and requires milliseconds even for very low driving frequencies while the reaction time is the same as the Fixed Band IIR Filter at high frequencies.

Thus, the Fixed Bandwidth + Proportional Filter works effectively where traditional analog tracking filters fail to work.

Filter performance comparison

Filter Type	Reaction Time	Harmonic Attenuation	Bandwidth
Proportional	Excellent	Excellent	Excellent at low frequencies, Acceptable at high frequencies
Fixed Bandwidth IIR	Good	Not ideal at low frequencies	Not ideal at low frequencies, Excellent at high frequencies
Proportional + Fixed Bandwidth IIR	Good	Excellent	Excellent

In conclusion, assessing the endurance of a device through shaker-induced vibration is a widely used technique that poses potential damage to the Device Under Test. The implementation of a secondary shutdown protection system is crucial to mitigate the risk of substantial damage.

The Proportional Filter is the preferred method of implementation due to its very short reaction times.

In scenarios where a narrow band is required at frequencies higher than 100 Hz while operating effectively at 10 Hz or lower, the Crystal Instruments Fixed Band + Proportional Filter provides optimal functionality as a shutdown protection system.

Sigma Clipping is Improved by Intelligent Clipping Algorithm

Sigma Clipping limits the peaks of the drive signal distribution based on a factor of sigma. Starting from the 11.1 release, it is improved by an Intelligent Clipping algorithm so that the loss in dynamic range of the control is minimal. The algorithm also massively reduces (-40 dB) the amplitude of high frequency content to the drive signal. This comparison is with respect to the drive clipping algorithm used in our older implementation.

Improved Dynamic Range

A dynamic range of a controller is a measure of the maximum and minimum value that can be controlled simultaneously. To expand further, consider Figure 1 below. With the intelligent clipping method,

the dynamic range of the drive signal (measured by the presence of a notch between 300 Hz – 700 Hz), is 30 dB better when compared to the drive signal with a sigma clipping value of 3 using the old method.

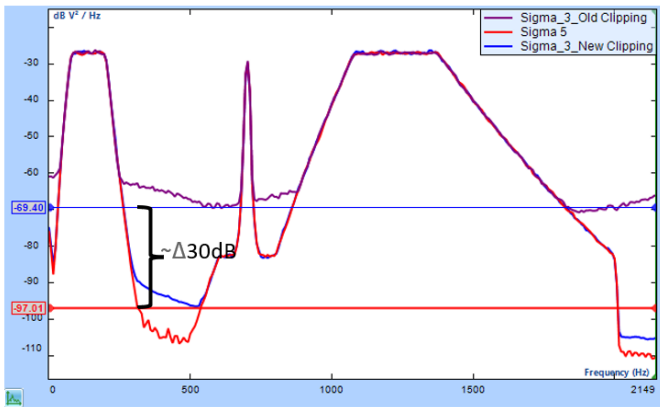

Figure 5. Drive Signals Auto Power Spectrum

Reduction of high frequency component to the signal

The consequences of limiting or hard clipping the peak values of signal are the addition of high frequency components to the signal as shown in Figure 2. This is a huge drawback considering the resonance frequencies of the DUT could fall in these high frequency contents and potentially damage the DUT. The intelligent clipping algorithm reduces the amplitude of high frequency content of the drive signal by 40 dB compared to the old algorithm.

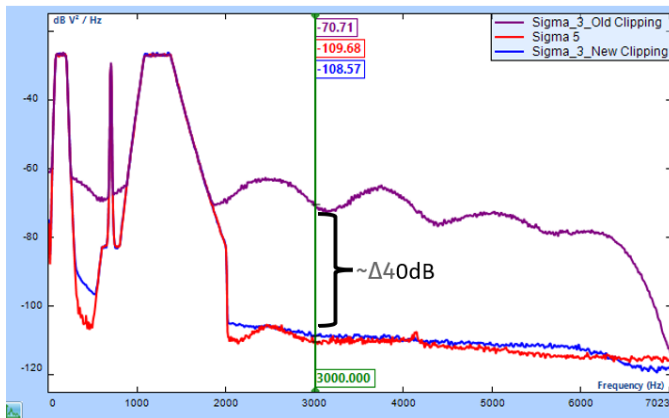

Figure 6. Drive Signal Auto Power Spectra to show high frequency components.

Signal Viewer

Signal Viewer is a lightweight standalone software that displays signals acquired by Crystal Instruments' products. It is an .exe file and does not require installation. Simply run the file, and it provides the same user interface as EDM, along with the signal display and report builder features found in EDM.

Import and Display Signals

A main feature of Signal Viewer is to display signal data generated by VCS and other EDM software.

Signal Viewer provides users with a default view of the left side and the Data Files panel. Users can click buttons to open and remove files. Atfx files can also be imported here:

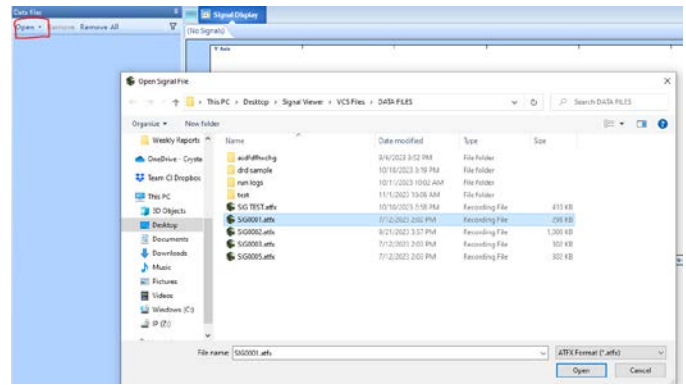

The files will open in the panel and can be expanded to display the internal signals, including time and frequency signals. Users can display these signals in the open chart window by dragging the signals into the view. Alternatively, right-click the chart window and select the "Add/Remove Signal" option:

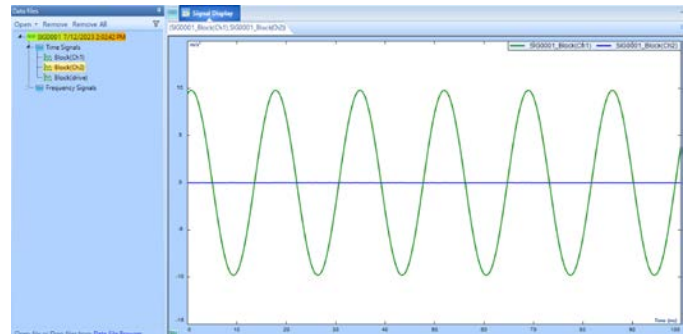

Users can also open new tabs and name them accordingly to organize displays:



Filter Data Files

Signal Viewer now includes a new filter for Data Files.

Click the Filter button in the top right corner of the Data Files panel to open the Filter Panel:

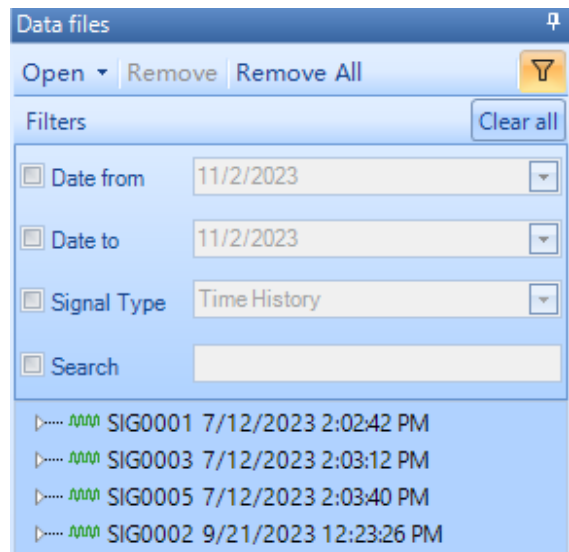

Users can filter the signal files according to a Start Date and End Date. There are also options to filter the Time and Frequency signals by Signal Type and a Search option.

The features allow users to easily filter results for search and display:

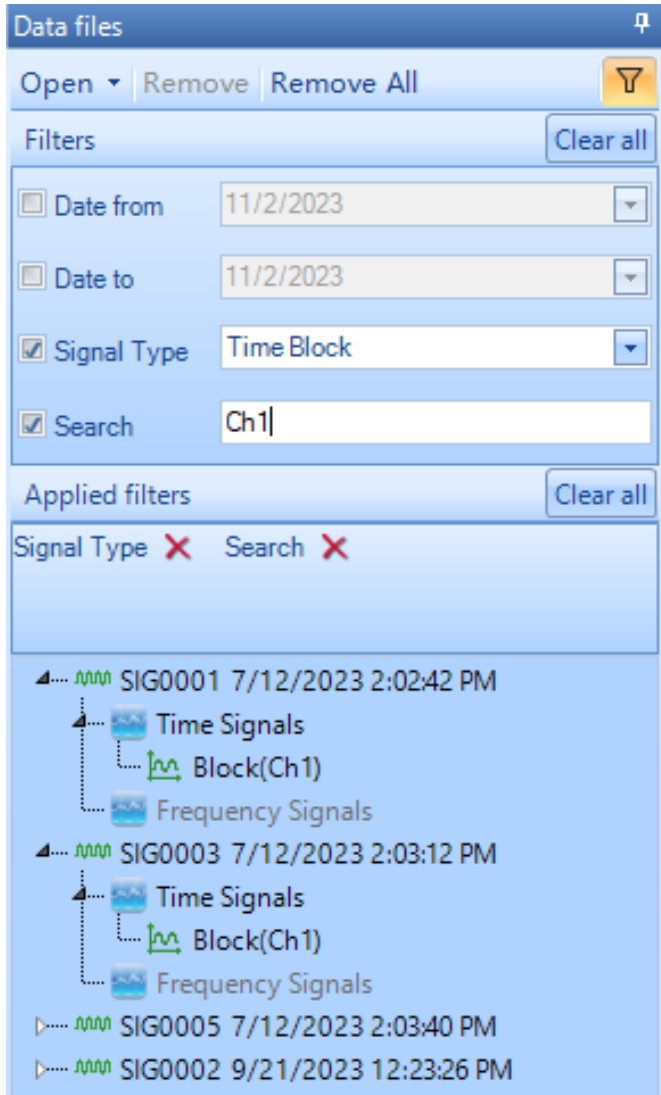

Export Data Files

Users can also export data files for external use.

Inside the Data Files panel, right click on any Signal file and select the "Export" option. Several file formats are available to export the signal data:

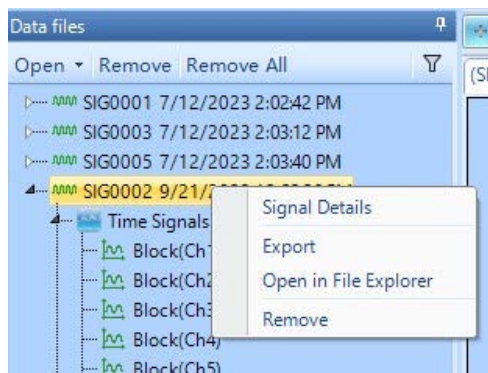

Executing OMA Using Time Stamp Technology on Multiple CoCo Devices

The handheld CoCo conveniently and accurately records measurements in the field. Its rugged system features a compact display for quick, easy, and accurate data recording and analysis. This powerful hardware system combined with patented GPS time synchronization (time accuracy of 100 ns) technology and Operational Modal Analysis can be used to study the dynamic characteristics of large structures, such as bridges and buildings. The testing plans and the 3D model geometry created in EDM Modal can be transferred onto multiple CoCo devices to acquire the ambient vibration responses. The GPS time stamp technology will assist in synchronizing the measurements carried out simultaneously on the various handheld systems. The EDM Modal software will post-process and analyze the data to provide the modal parameters of the test structure. This robust workflow provides a seamless integration of the operational modal analysis process.

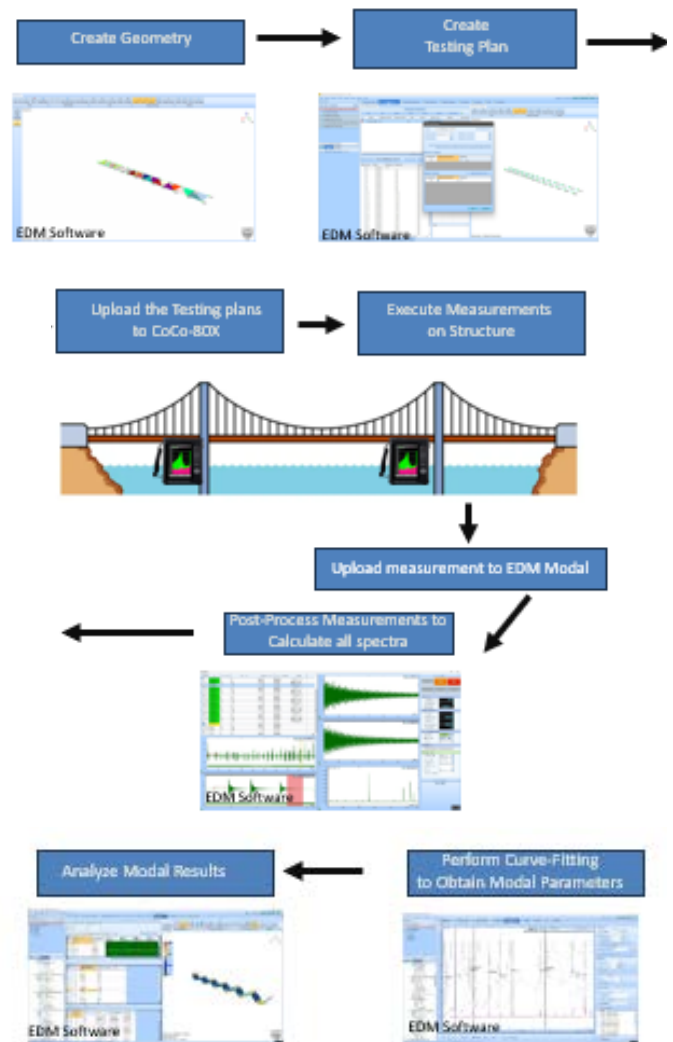

Data File Browser

This is an independent application developed at Crystal Instruments to help users select saved recordings and signal files from their PC. The application is available by default when EDM / PA v11.1 is installed, and the user can find it while importing a recording or signal as a source file. It indexes the file system for all recordings and saved signals to display it on the User Interface as shown in the following figure. Basic information such as name, time, and date of the signal saved, etc. is displayed when the cursor is hovered over a recording.

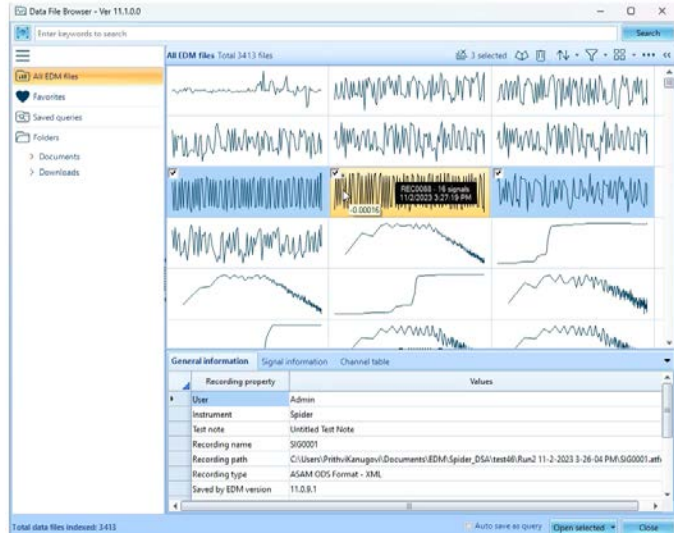

The key pain point addressed with this application is to prevent users from searching through their file directory for a recording. Instead, users can simply locate the recording in the UI as shown in the preceding figure and drag it into their source files list.

Spider runs as Power Stabilizer System

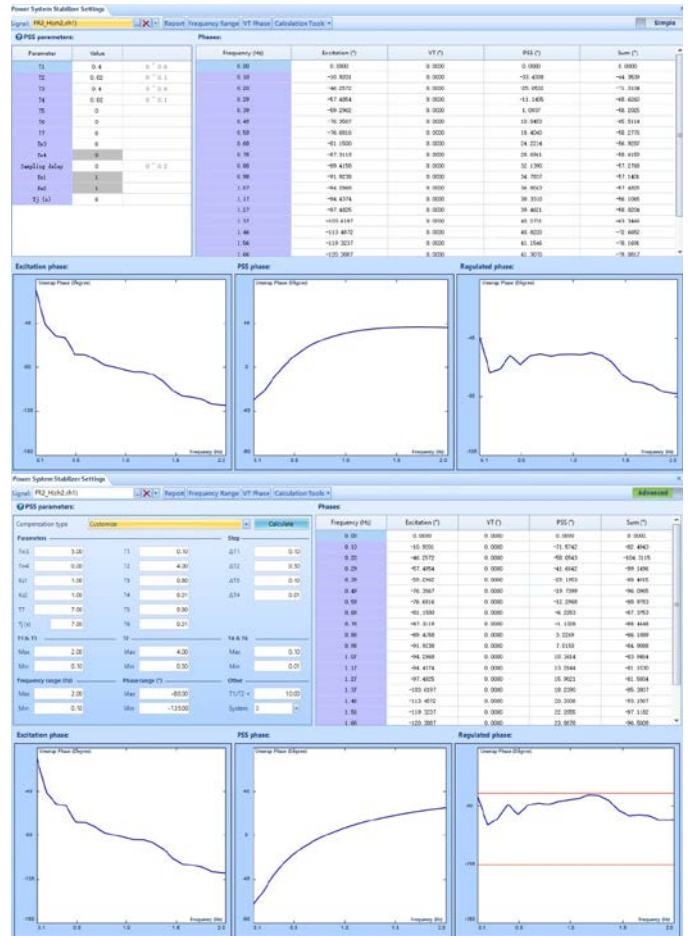
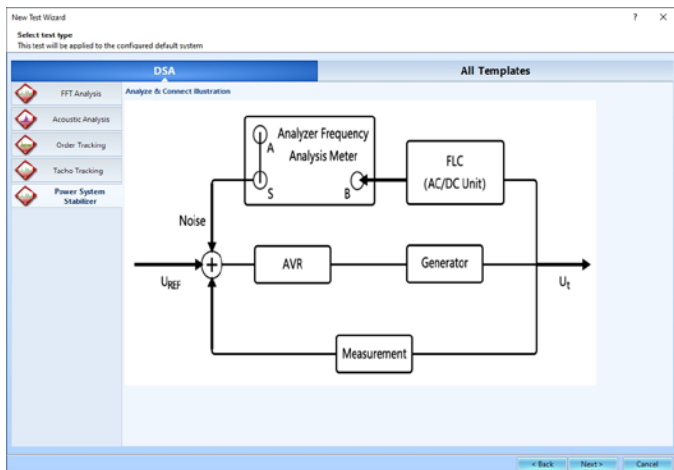

New EDM CoCo Mode

The user interface is redesigned to function more intuitively.

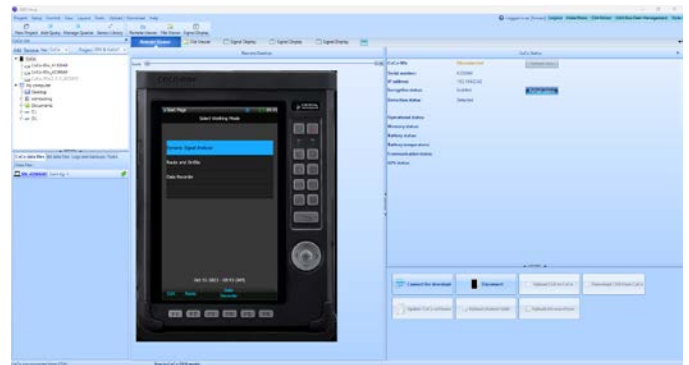

Control Multiple Units

The software now provides a straight-forward method to switch control among CoCo and GRS devices.

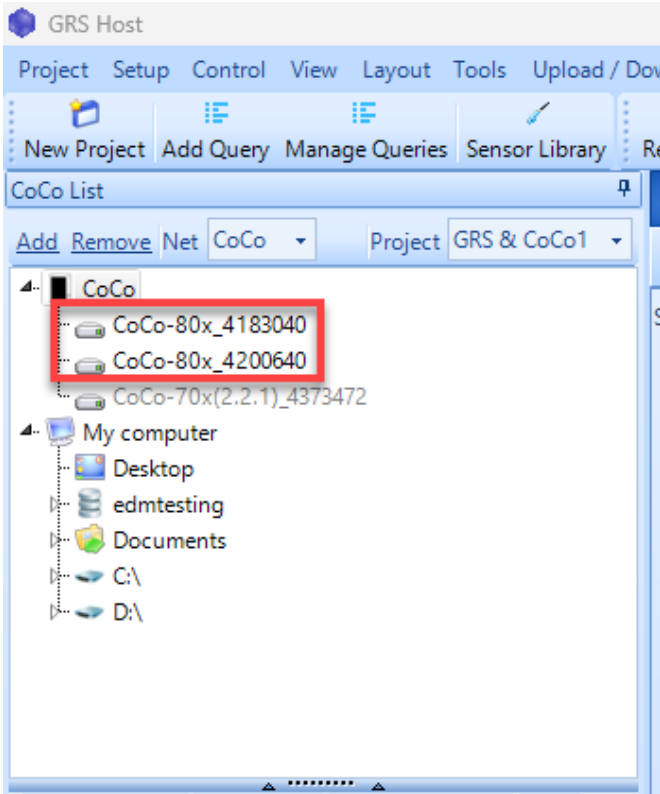

Batch Operations

It can become tedious to upload configurations and download data with multiple units deployed. Batch operations is a robust solution that allows users to upload and download files simultaneously from multiple devices, streamlining the data management process.

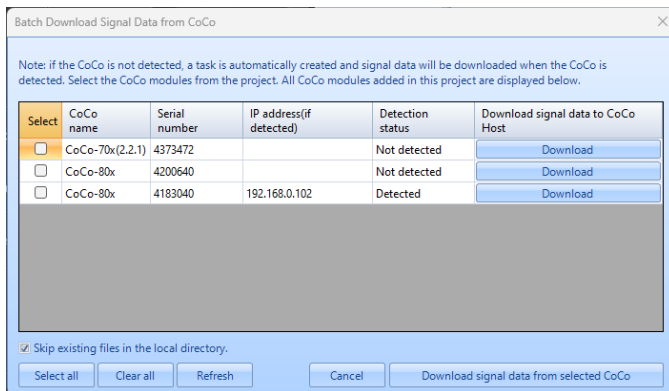

Time Stamped Signals

GPS time-stamping technology is introduced to the CoCo systems. When the time accuracy of a sampling clock demands millisecond resolution, the digital input paths of the data acquisition system, especially its ADC, must be designed with control from a more accurate time base, such as GPS or IEEE 1588 PTP (precision time protocol). This newly implemented time stamping technology allows users to synchronize measurements from separate CoCos to perform spectral analysis, among other signal processing functions. Users can view time stamped data on EDM CoCo DSA and synchronize multiple time stamped datasets using Post Analyzer.

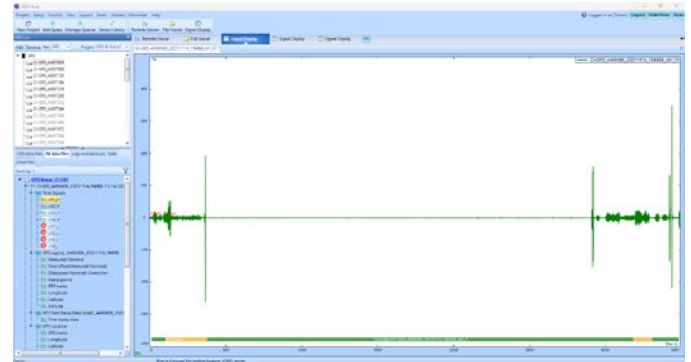

Before Synchronization:

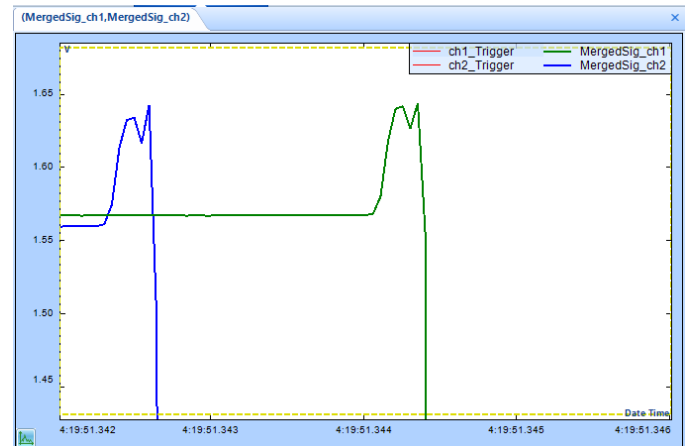

After Synchronization:

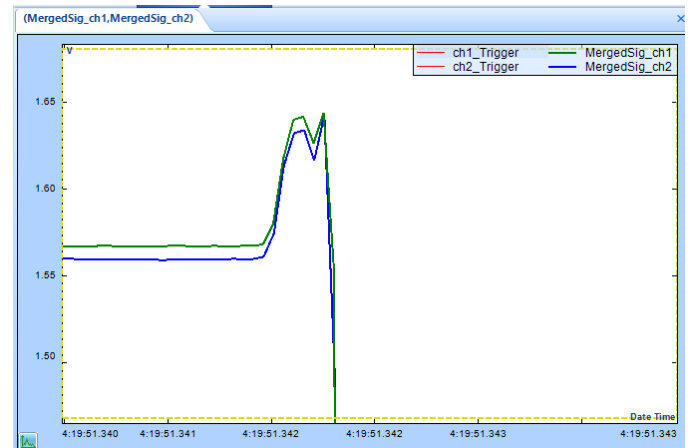

File Viewer

The new file viewer design provides a cleaner interface to locate and manage files on the CoCo and GRS.

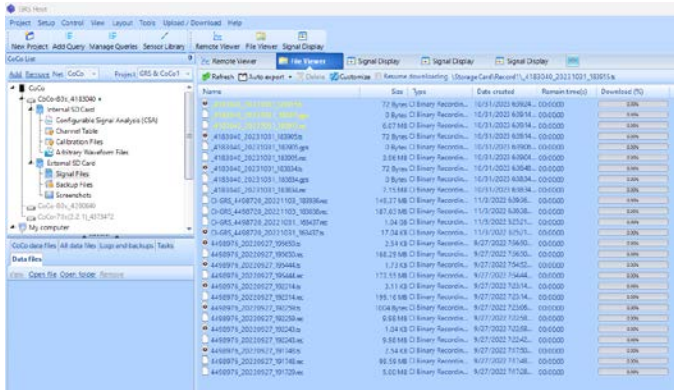

Sensor Library

A new sensor library allows users to download and upload sensor characteristics to the CoCo.

Name	Manufacturer	Model	Description	Sensor SN	Sensor type	Input mode	Quantity	Unit	Sensitivity
sensor									
Template_27_Microphone_BuiltInFrampipier	PCB Piezotronics	373		147106		SEPE	Acceleration	ms ²	0.0002(mV/(ms ²))
Template_27_Microphone_BuiltInFrampipier	PCB Piezotronics	373		152720		SEPE	Sound Pressure	Pa	12.1693(mV/Pa)
Template_27_Microphone_BuiltInFrampipier	PCB Piezotronics	130		30118		SEPE	Sound Pressure	Pa	36.4161(mV/Pa)
Template_27_Microphone_BuiltInFrampipier	PCB Piezotronics	130		35083		SEPE	Sound Pressure	Pa	40.5047(mV/Pa)

New Blade Fatigue Testing Features

Blade Fatigue Testing was initially introduced in the EDM 10.0 release. Since then, Crystal Instruments has received feedback from several users recommending improvements. Our team attentively reviewed their suggestions and implemented the following enhancements.

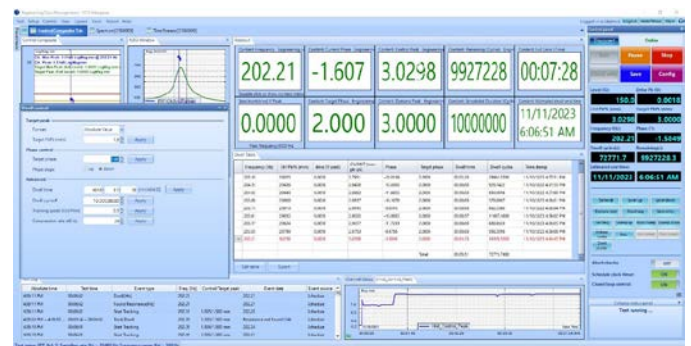

Encryption

Users can encrypt SD cards with EDM software.

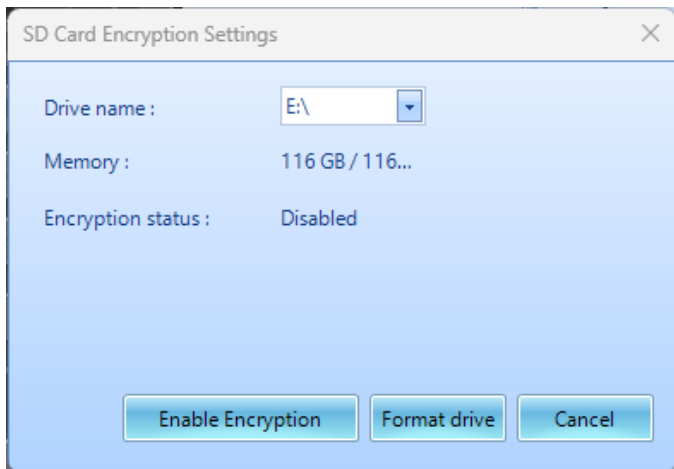

Configure Control Channel for Sweep and Dwell in One Place

Configure separate control channels for sweep and dwell within the same input channel table. Eliminates the need for manual updates before each sweep or dwell operation.

Input Channels	Sensors	Measurement quantity	Engineering unit	Sensor	Max. analog range	Sensitivity	Sweep channel type	Dwell channel type	Input mode	High-pass filter Fc (Hz)
1	ON	Acc	Acceleration	N/A	20.00	100 (mV/g)	Monitor	Monitor	AC-Single End	0.5
2	ON	Dis	Displacement	N/A	20.00	10 (mV/mm)	Monitor	Control	AC-Single End	0.5
3	ON	Acc	Acceleration	N/A	20.00	10 (mV/g)	Control	Monitor	AC-Single End	0.5
4	ON	Dis	Displacement	N/A	20.00	100 (mV/mm)	Monitor	Monitor	AC-Single End	0.5
5	ON	Acc	Acceleration	N/A	20.00	100 (mV/g)	Monitor	Monitor	AC-Single End	0.5
6	ON	Dis	Displacement	N/A	20.00	100 (mV/mm)	Monitor	Monitor	AC-Single End	0.5
7	ON	Acc	Acceleration	N/A	20.00	100 (mV/g)	Monitor	Monitor	AC-Single End	0.5
8	ON	Dis	Displacement	N/A	20.00	100 (mV/mm)	Monitor	Monitor	AC-Single End	0.5

Arbitrary Waveform Editor

Users can now create or edit waveforms with the CoCo-DSA software. Easily upload waveforms to the CoCo and generate a custom signal through the output channel.

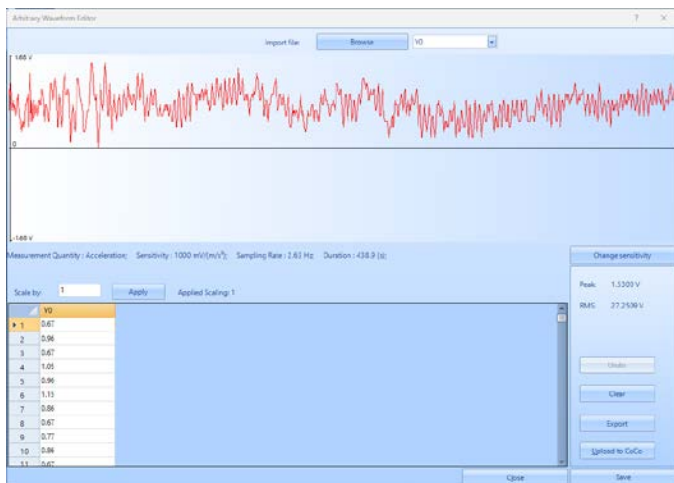

Configure Profile for Sweep and Dwell in One Place

Preconfigure distinct profiles for sweep and dwell to eliminate the need for manual updates each time before performing either sweep or dwell.

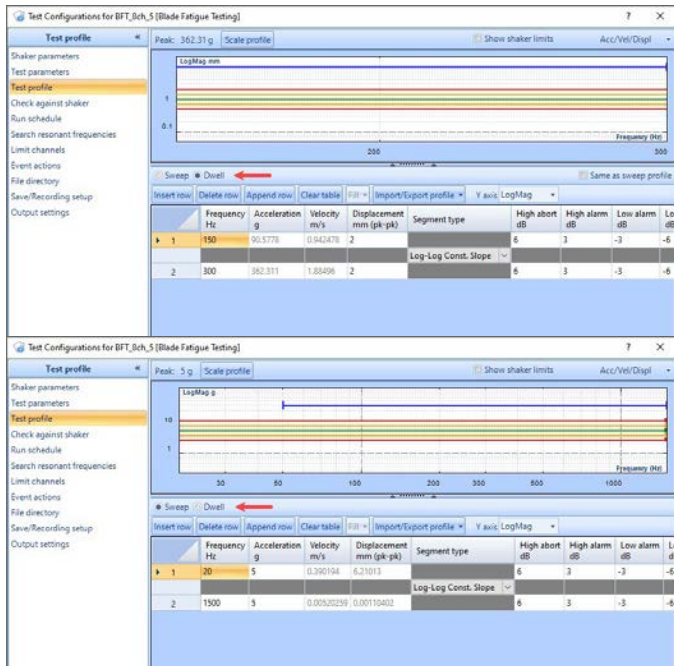

Manual Search, Automatic Search, and Adjust Dwell Parameters during test

Dwell frequency, target peak, and target phase can be adjusted before initiating the dwell and tracking process, as the resonance identified during the sweep may not be accurate enough, necessitating manual adjustments.

Additionally, this feature allows users to manually search for resonance if the automatic search during dwelling does not meet expectations.

Users can update certain dwell parameters in the Advanced section while a test is running in case the original schedule does not align with the test requirements after initiation.

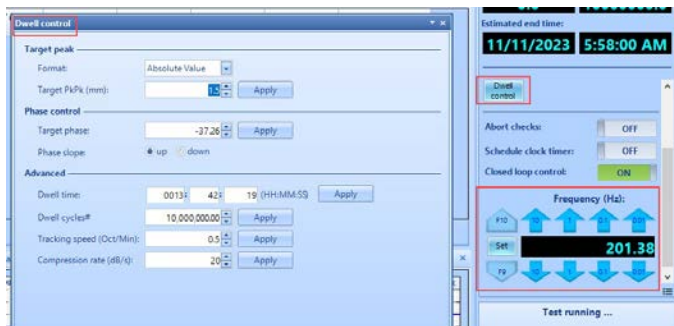

Readout for BFT

A swift and customized numerical display presents essential test status information.



Dwell Table

Keeps records of necessary information for each dwelling frequency. Each record can be saved periodically or when a resonance frequency changes. The table can be exported to a file.

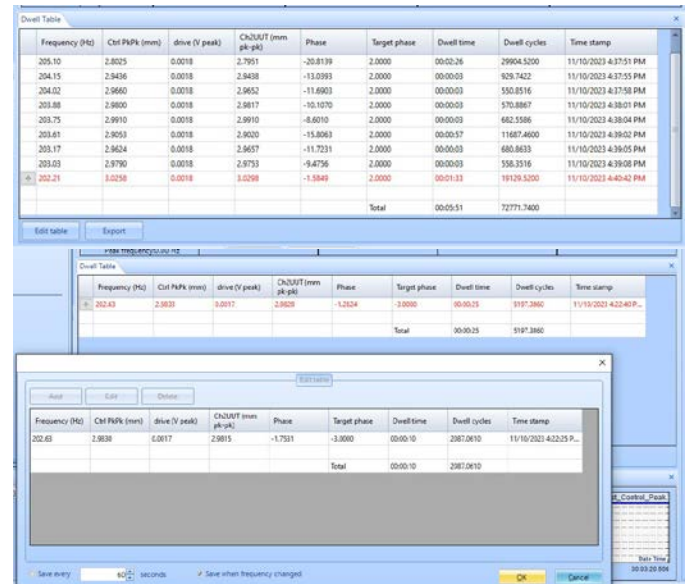

4-Shaker MIMO Random Control

MIMO Random now includes 4x4 (four shaker configuration) control.

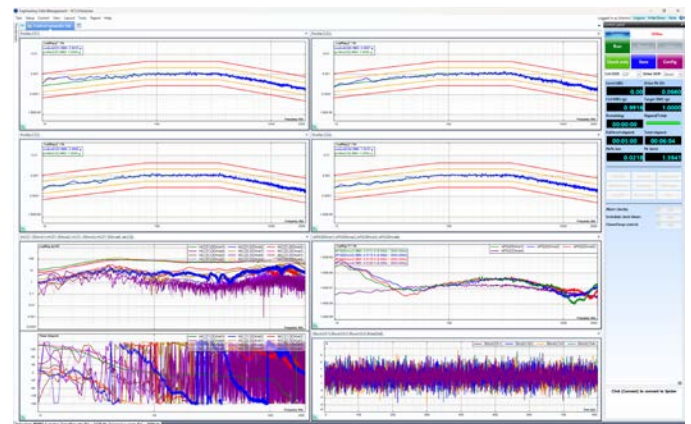

NEW FEATURES

New Features in EDM-VCS Vibration Control Software

More User Notes in Checklist and Reports

User Notes are more prominently featured in the Checklist (before running a test) and reporting feature. Additionally, the Run Folder name can be set according to the input User Notes values.

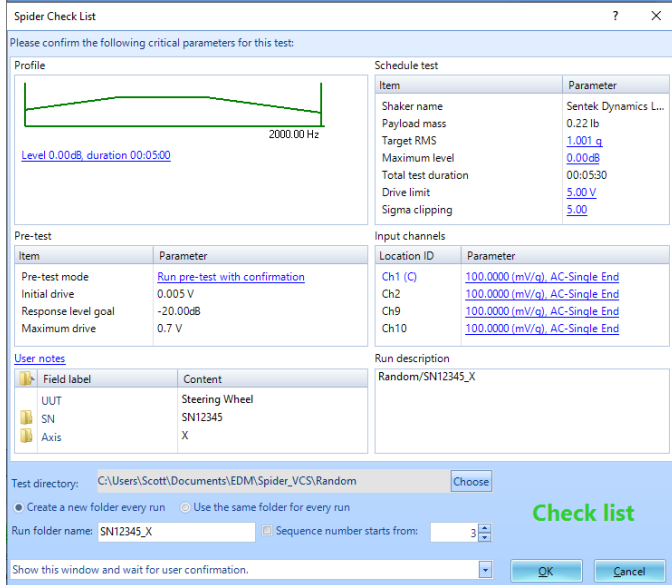
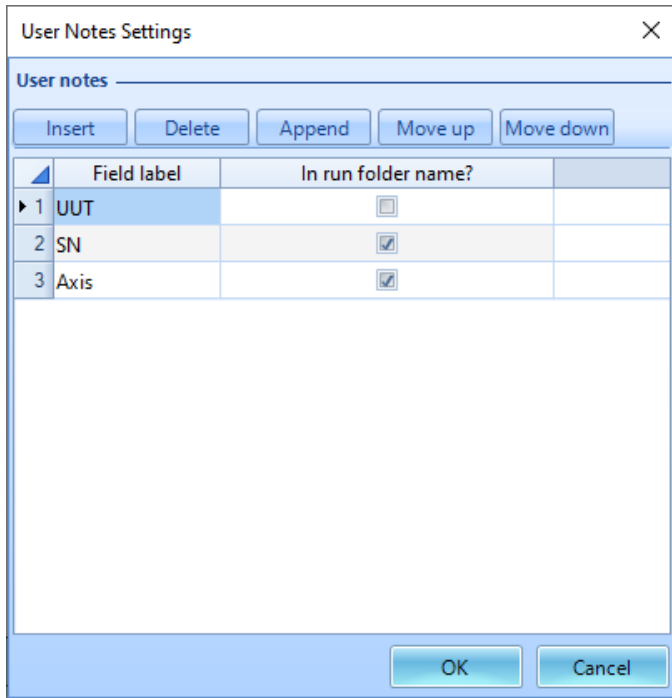

Burst Mode in ROR

In VCS SORROR, users can modify RoR and SoR profiles. Previously, there was a burst mode implemented for SoR profile, where the tones would start and stop rapidly based on user settings.

Now, RoR Profile also has this feature. Simply open Config > Run Folder profile, and scroll toward the bottom to the "Burst (gunfire)" section:

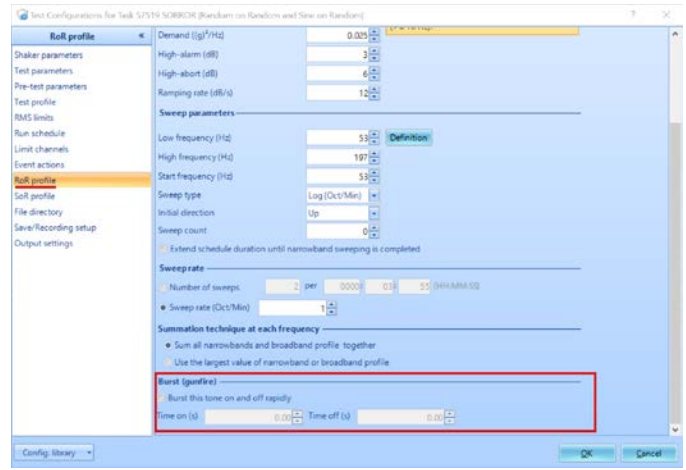

New Features in MIMO/MESA Vibration Control Software

CAN Bus support for MIMO and MESA control types

CAN Bus extension is supported in all MIMO and MESA control types. This feature allows testing for automotive applications at a new level.

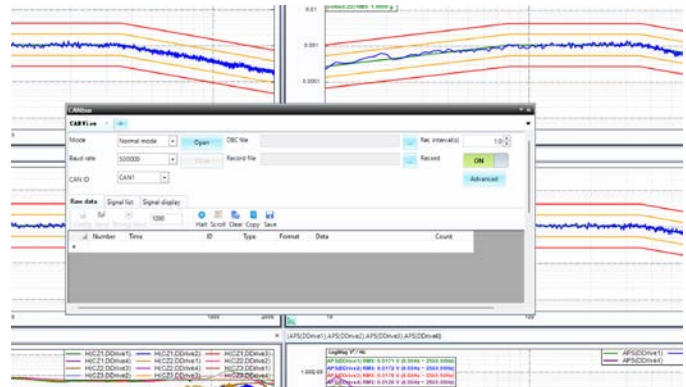

New Features in EDM Dynamic Signal Analysis

Measure histogram, crest factor and Kurtosis

EDM DSA software can now generate histograms from time blocks. Additionally, crest factors and Kurtosis can be derived histograms and displayed in EDM.

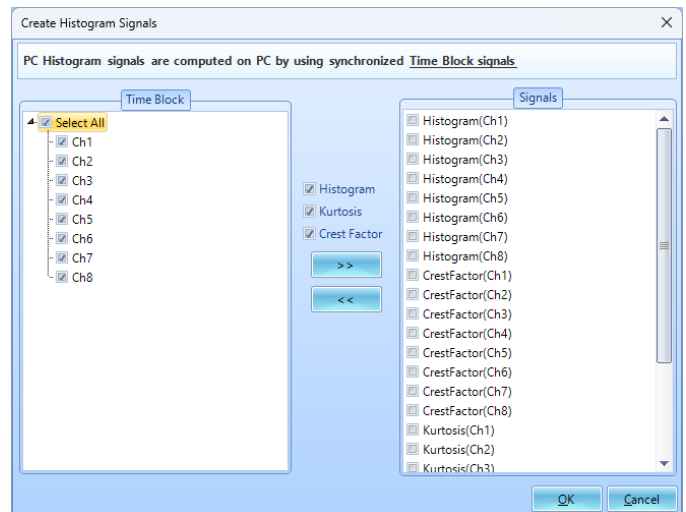

Histograms:

EDM DSA can now plot a live signal of Histogram from all input channels. It gives the user control over the max/min range and number of bins. This is computed on the PC and not on the board, hence does not utilize any DSP resources.

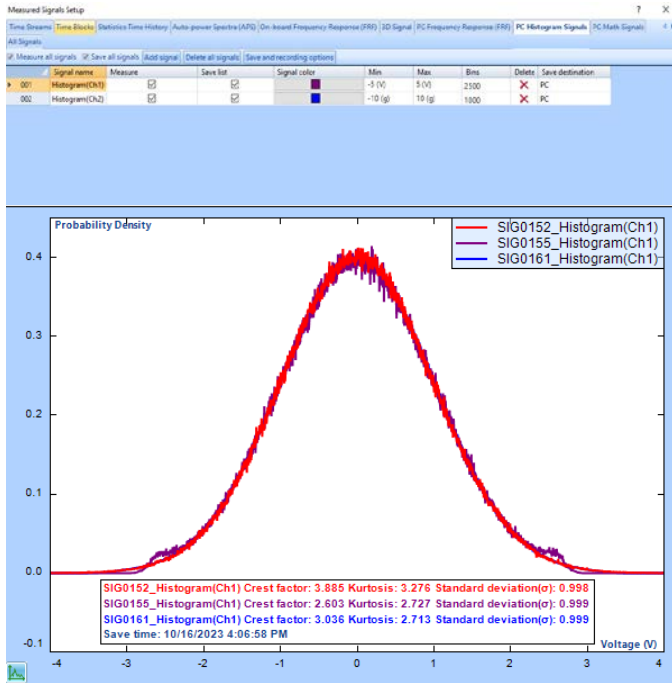

Crest Factor and Kurtosis Time histories:

Similar to Histograms, Crest Factor and Kurtosis from each block is measured on the PC and is displayed as a live signal. Users can view time histories.

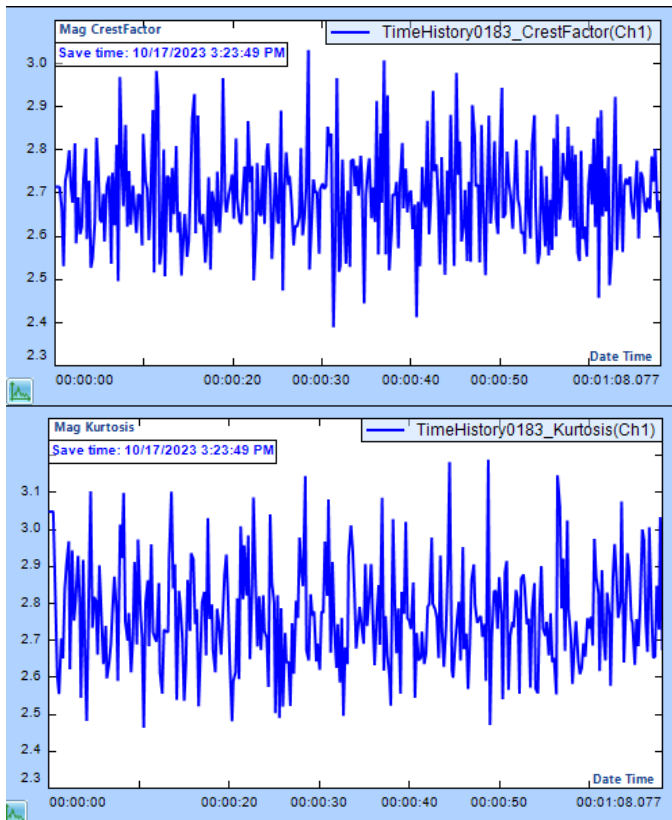

Spiders automatically run a test in Black Box mode after powering on

All Spiders are now designed to automatically execute a test upon powering on, if in Black Box mode. The test to be executed is defined in EDM and uploaded to the Spider front-end.

Extend recording duration when multiple triggers are received, or multiple limits are exceeded.

Numerous events can be linked to Start Recording commands. In situations where a recording is in progress, the Spider can be configured to ignore upcoming triggers/limits or instead extend the recording duration.

Tripartite Response Spectrum

Display Tripartite Response Spectrum of acceleration, velocity, and displacement.

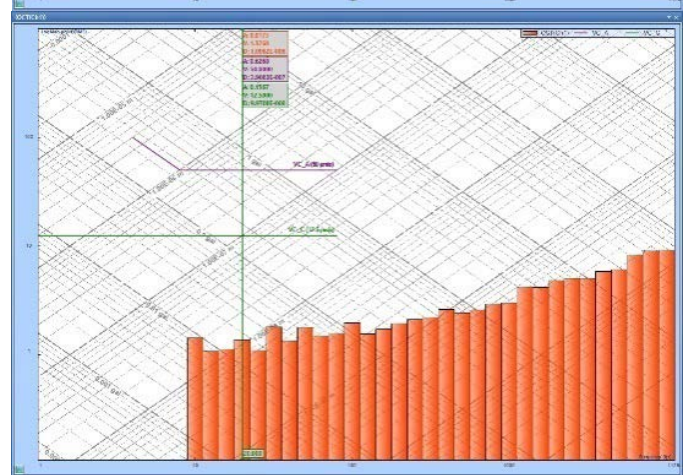
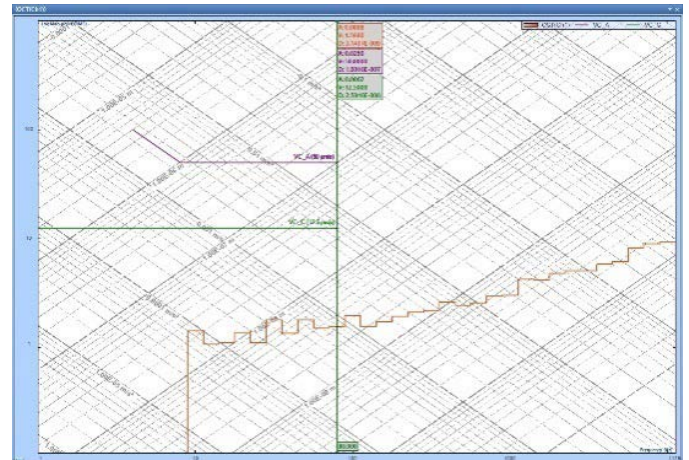
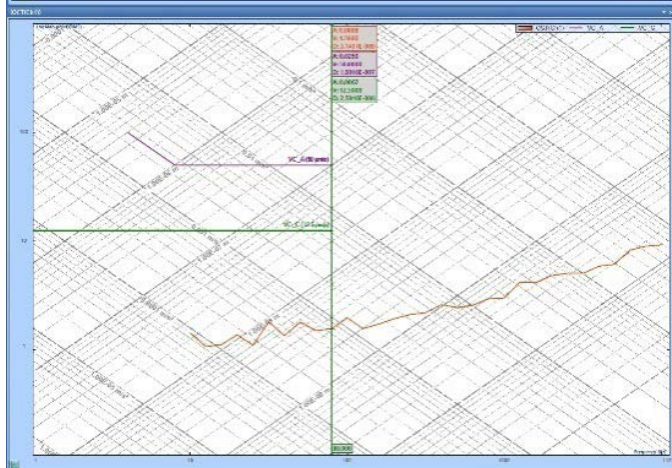
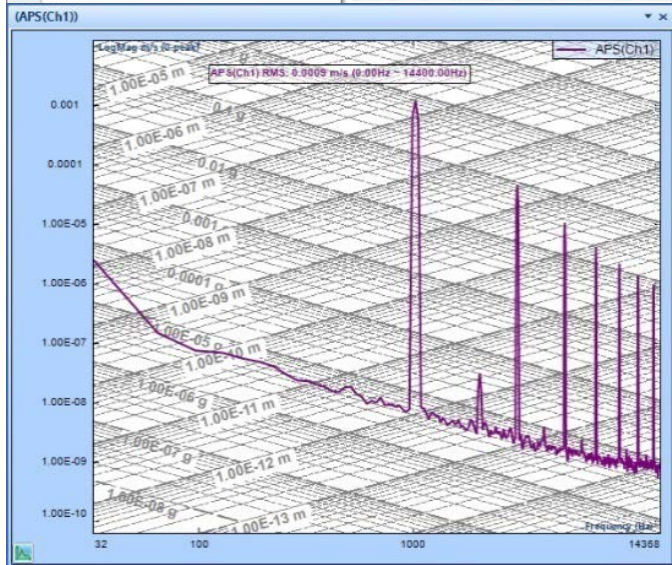
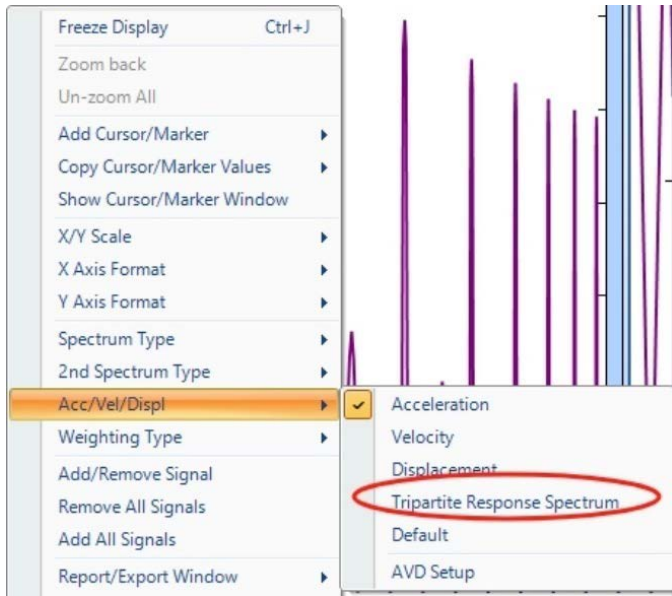

DSA - SRS Statistic Window Improved

The DSA SRS statistic window now includes a tolerance tab for MIL STD 810 calculations and analysis. This feature calculates the percentage of which a measured SRS is within the abort and alarm reference limits as well as the degree to which it exceeds the reference profile.

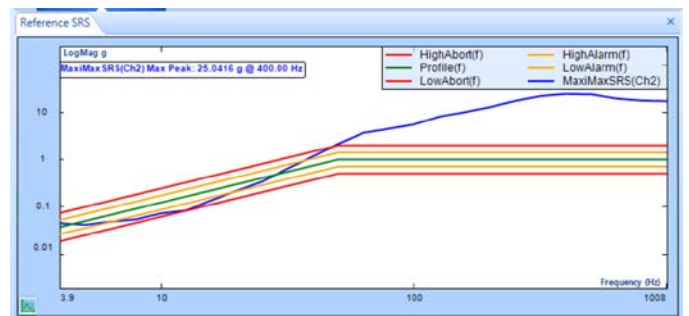

SRS Statistic Window

Min / Max Tolerance

Evaluate tolerances across all frequencies

Custom frequency range: 10.00 ~ 500.00 Hz

Calculate percentages by point count

Configure signals

Name	Exceed profile	Within Alarm	Within Abort
PosSRS(Ch2)	75.00 %	12.50 %	25.00 %
NegSRS(Ch2)	68.75 %	18.75 %	37.50 %
MaxiMaxSRS(Ch2)	75.00 %	18.75 %	37.50 %

The percentage calculation can be based on the entire frequency range or on a custom range. Right clicking the signal table allows

users to select certain signals of interest. Multiple signals may be displayed on top of the reference profile.

New Features in Post Analyzer PA -SRS Statistic & tolerance window

SRS statistic and tolerance window has now been added to Post Analyzer SRS test. The SRS tolerance window is a feature that allows the analysis of an SRS signal based on the MIL STD 810 proc III. This feature calculates the percentage of which a measured SRS is within the abort and alarm reference limits as well as the degree to which it exceeds the reference profile.

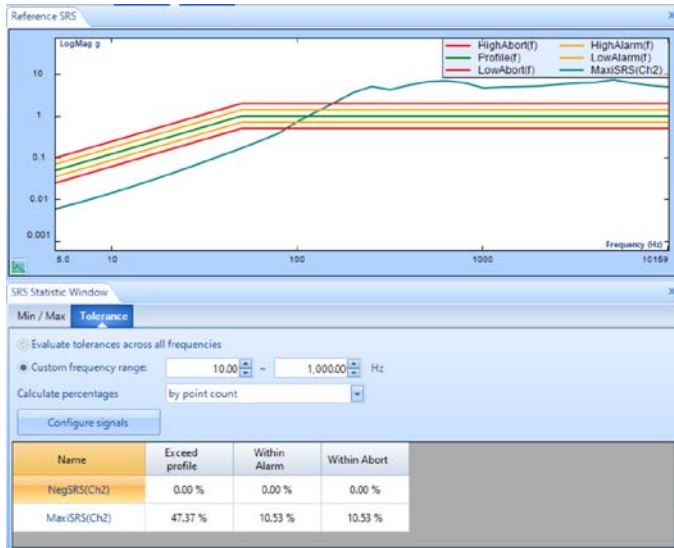

The percentage calculation can be based on the entire frequency range or on a custom range. Right clicking the signal table allows users to select certain signals of interest. Multiple signals may be displayed on top of the reference profile.

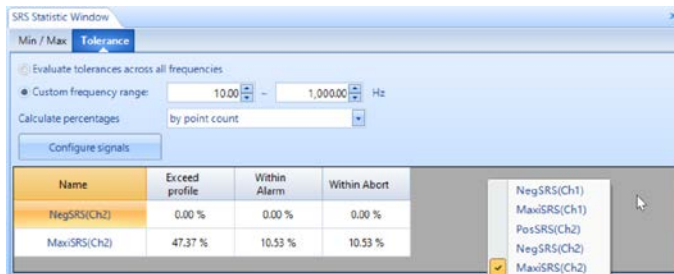

New General Features

Support 1V range on Spider-80SG/80SGi/80Gi in all EDM Applications

Actions	On/Off	Location ID	Measurement quantity	Engineering unit	Sensitivity	Input mode	Input range
1	On	Ch1	Voltage	V	1000 (mV/V)	DC-Single End	Auto
2	On	Ch2	Voltage	V	1000 (mV/V)	DC-Single End	Auto
3	On	Ch3	Voltage	V	1000 (mV/V)	DC-Single End	Auto
4	On	Ch4	Voltage	V	1000 (mV/V)	DC-Single End	Auto
5	On	Ch5	Voltage	V	1000 (mV/V)	DC-Single End	Auto
6	On	Ch6	Voltage	V	1000 (mV/V)	DC-Single End	Auto
7	On	Ch7	Voltage	V	1000 (mV/V)	DC-Single End	Auto
8	On	Ch8	Voltage	V	1000 (mV/V)	DC-Single End	Auto
9	On	Ch9	Strain	µε	N/A	DC-Differential	10mV
10	On	Ch10	Strain	µε	N/A	DC-Differential	10mV
11	On	Ch11	Strain	µε	N/A	DC-Differential	100mV
12	On	Ch12	Strain	µε	N/A	DC-Differential	10mV
13	On	Ch13	Strain	µε	N/A	DC-Differential	10mV
14	On	Ch14	Strain	µε	N/A	DC-Differential	10mV
15	On	Ch15	Strain	µε	N/A	DC-Differential	10mV
16	On	Ch16	Strain	µε	N/A	DC-Differential	10mV

MAJOR IMPROVEMENTS

EDM Vibration Control Software

Sine Oscillator supports up to 512 channels



Test Profile Tolerance editing improvement

Improved usability features for bulk editing the breakpoint and tolerance values for a given Test Profile, applied in Random, Sine and SRS Synthesis test types. Use right-click menu options such as "Copy Breakpoints" / "Paste Breakpoints" or "Copy Column" / "Paste Column", as well as simplified CSV import/export flows.

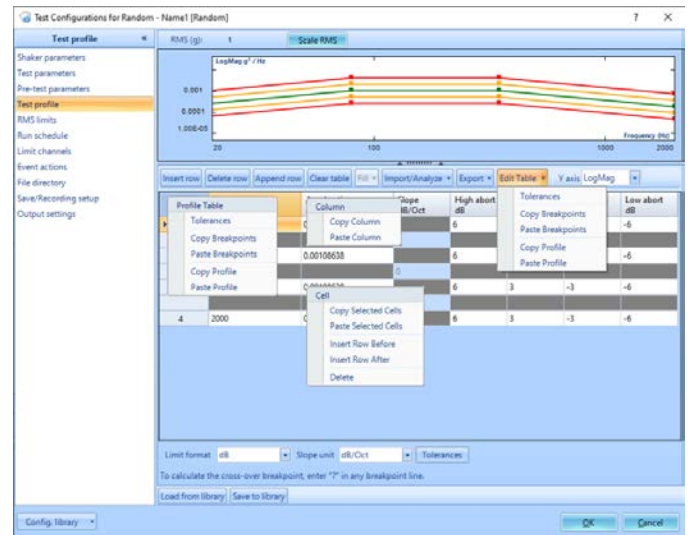

Report Builder improvements

Report Builder provides direct options to configure Title and User Notes settings, as well as Measurement Status entries within testing results. Reports can be generated directly from the Report Options window.

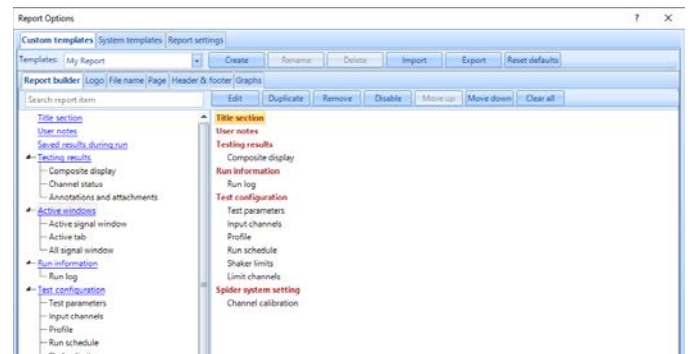

Report, Report Builder (all app modes) to read in run log (origlog) from file system:

After Signal Viewer was designed, it was decided to bring more testing and run information over through the atfx files. This includes the run log, which is taken directly from the run log in VCS while a test is running.

This led to some issues, however, since the run log can become very large for long runs.

Instead, the idea was born to simply take along the “.origlog” file with the atfx file, and the log can be read separately from there.

The best example for this is in Signal Viewer. When creating a report in Signal Viewer for a specific signal file, since the run log is separate, it must be chosen separately by the user:

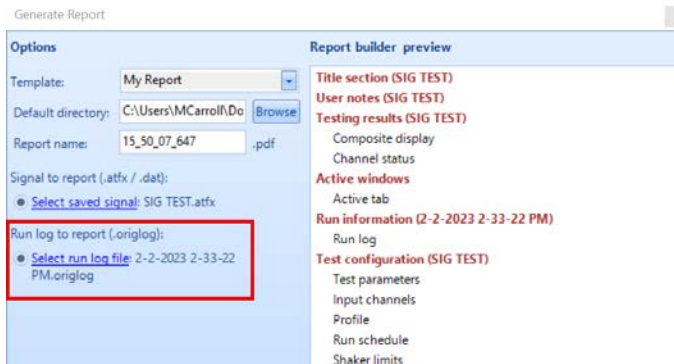

Report, When EDM generates a report, the report contents can be appended to the word file selected by a user

When generating a report in VCS or other, the user now has the option to choose an additional Word file to append to the end of the report. This is for the convenience of the user and can be accessed in the Report Settings.

In VCS, go to the top toolbar to the Report menu and go to Report > Report Settings.

Once the menu opens, users can select the option “Append selected word files to the report”:

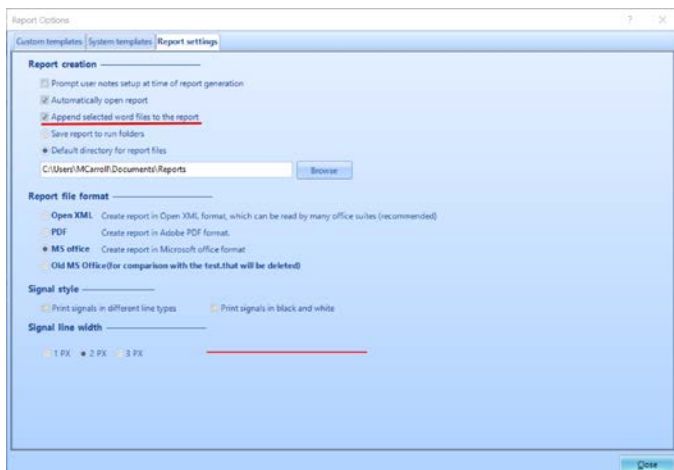

Once this is selected, a menu will appear to ask which files to append when generating a report:

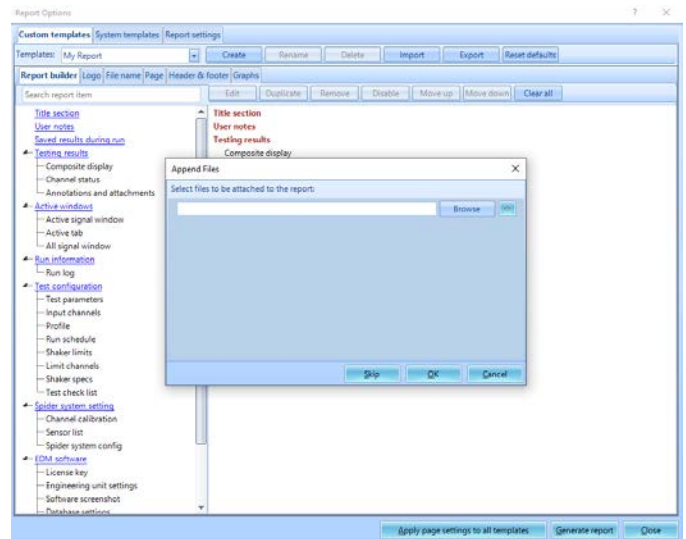

From there, clicking OK will generate the report with the chosen word file(s) appended.

Other Improvements

Sine Oscillator, added a frequency increment of 0.01 Hz and removed 100 Hz

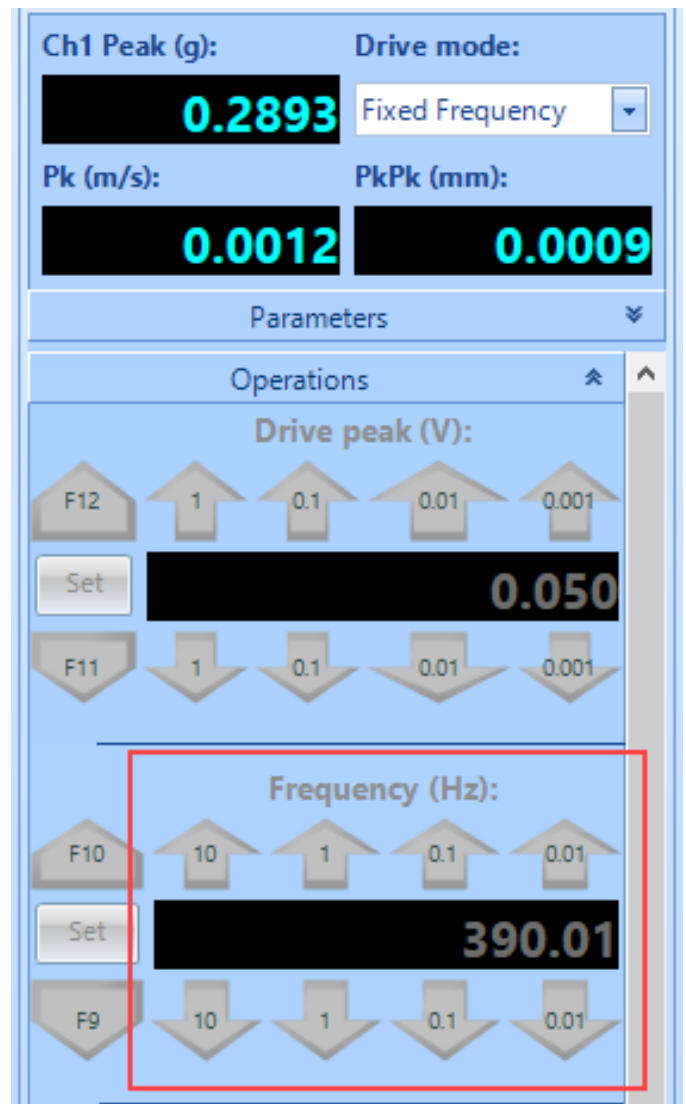

Memory optimization for Shock/TTH/SRS tests

Notes for creating a Vector RSS signal and an Overturning Moment signal

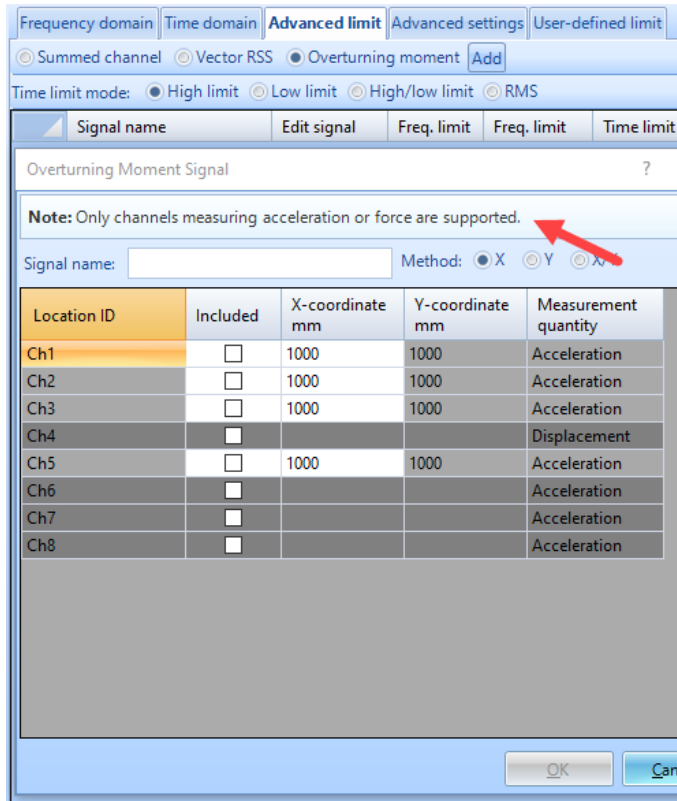

Improvements in Random

The Ramp Up rate and Level change rate can be reduced to 0.1 dB/s to better support hydraulic shakers.

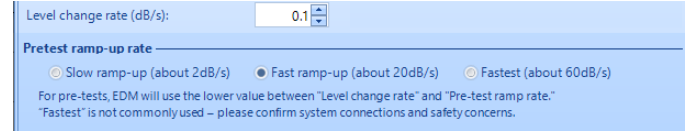

Measure, display, and save Kurtosis of each input signal.

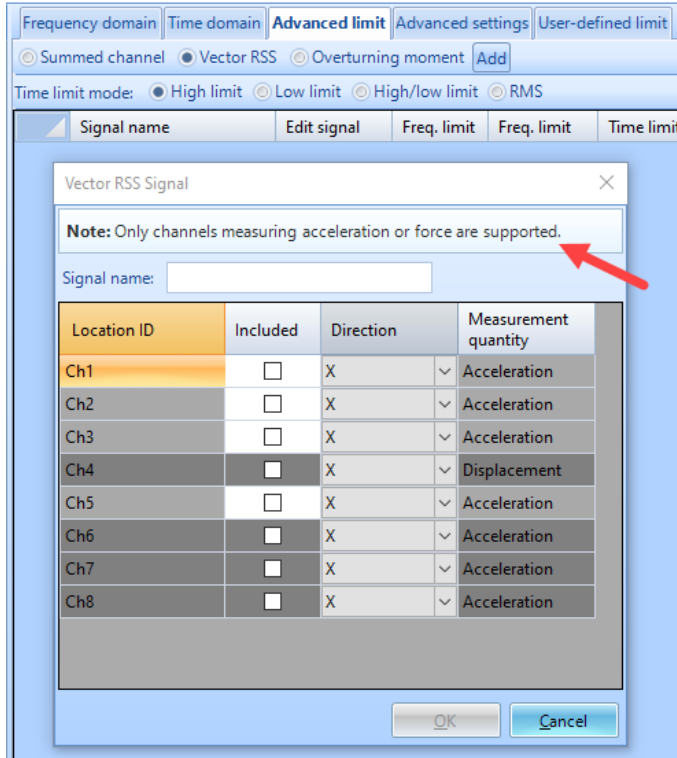
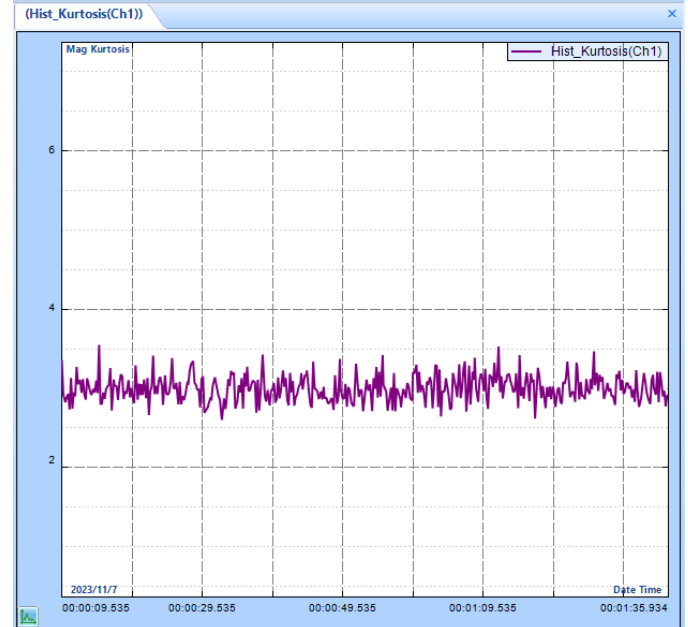

Improvements in SoRRoR

SoR/RoR RMS Limits support % or dB

Users can set the limits manually For Random tests inside the RMS Limits panel in Config. This can be done using EU units, percentage, or dB units.

SoR and RoR tests previously did not have this feature, and instead only supported EU and percentage.

Now, SORROR tests should match this feature with a slight difference. Since Sine and Random tones can be added to the run schedule, the high limits may adjust accordingly. To adjust for this, in RMS Limits, the percentage and dB values for high alarm and abort are based on the overall RMS (including tones), and the same values for low alarm and abort are based on the standard profile RMS.

Import .wav files to VCS as a TWR profile

Control RMS limits during test

- Calculate based on the table
- Enter manually (g)
- Enter manually (dB)
- Enter manually (%)

	(g)	(dB)	(%)
High abort	4.743	(+) 6.00	199.5
High alarm	3.359	(+) 3.00	141.3
Overall RMS	2.377		
Profile RMS	1.001		
Low alarm	0.7084	(-) -3.00	70.8
Low abort	0.5013	(-) -6.00	50.1

As pictured in the preceding figure, with one sine tone and one random narrowband active in the run schedule, the overall and profile RMS values are different, and the high and low limits are adjusted based on overall and profile RMS respectively.

SoR Advanced Profile should support “Limit format” dropdown:

In VCS SORROR, users can choose to use an advanced profile when configuring the sine tones and random narrowbands. This allows users to define strict terms on how the tones and narrowbands will behave.

Inside the Advanced Profile menu, users can now use the “Limits format” dropdown menu to change the format of the limits. This can be changed between dB, percentage, and absolute value:

Frequency (Hz)	Acceleration (g)	Velocity (in/g/s)	Displacement (in/g/s²)	High abort (%)	High alarm (%)	Low alarm (%)	Low abort (%)
1	2.22943	0.00000	0.00000	199.5	141.3	70.79	50.12
2	100	0.00015	0.00000	199.5	141.3	70.79	50.12

Improvements in Shock/TTH/SRS/Earthquake Testing/ Transient Random

Sine Sweep Entry improvements

Previously, in VCS Swept Sine, changing the profile may have resulted in error if the new profile is outside of the defined range in the Run Schedule sweep.

Now, the Run Schedule has an updated design.

Previous design:

Updated design:

The main changes are in the “Sweep range” section. Here, the user can choose to simply sweep the profile up, down, or in a custom manner. When the test profile is changed in Swept Sine, this option will default back to “Test profile (up)”, so the user will not need to change the schedule manually.

Improvements in Shock/TTH/SRS/Earthquake Testing/ Transient Random

Displacement assisted channel (in Shock/TTH/SRS/Earthquake testing)

Add a displacement channel to enhance time waveform control for Shock/TTH/SRS/Earthquake testing. This addition improves control accuracy in both acceleration and displacement.

Actions	On/Off	Location ID	Measurement quantity	Engineering unit	Sensor	Max. sensor range	Sensitivity	Channel type	Input mode	High-pass filter Hz (Hz)
1	On	CH1	Acceleration	g	EEF_201A11	20 (V)	101 (mV/g)	Monitor	AC-Single End	Off
2	On	CH2	Acceleration	g	112B35-Z	20 (V)	10.442 (mV/g)	Control	AC-Single End	Off
3	On	CH3	Acceleration	g	B22A1-Z	20 (V)	8.68 (mV/g)	Monitor	AC-Single End	Off
4	On	CH4	Displacement	mm	N/A	20 (V)	400 (mV/mm)	Disp. Assist Control	AC-Single End	Off
5	On	CH5	Acceleration	g	N/A	20 (V)	100 (mV/g)	Monitor	AC-Single End	Off
6	Off	CH6	Acceleration	g	N/A	20 (V)	100 (mV/g)	Monitor	AC-Single End	Off
7	Off	CH7	Acceleration	g	N/A	20 (V)	100 (mV/g)	Monitor	AC-Single End	Off
8	Off	CH8	Acceleration	g	N/A	20 (V)	100 (mV/g)	Monitor	AC-Single End	Off

SRS Synthesis – UI refactor and cursor support

Intuitive improvements to the SRS Synthesis page includes added cursor support to view the shock response at a particular frequency, as well as iterating on just that cursor wavelet.

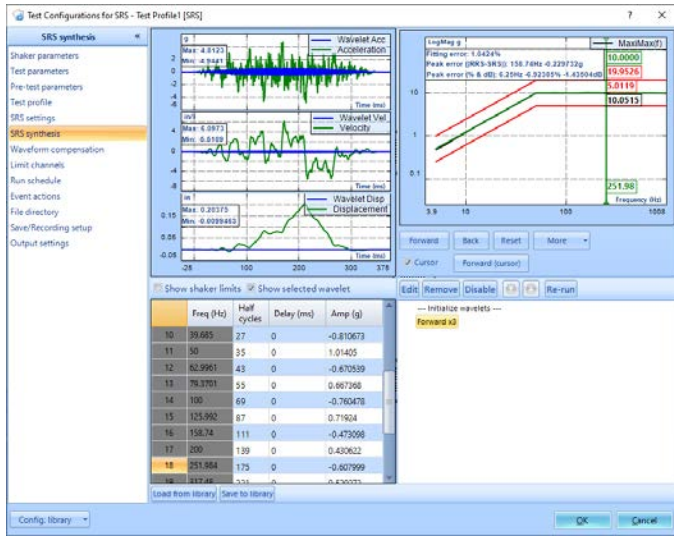

Includes the advanced profile of sine tone

If a Sine tone is enabled with an advanced profile, the profile table and display are included when a report is generated.

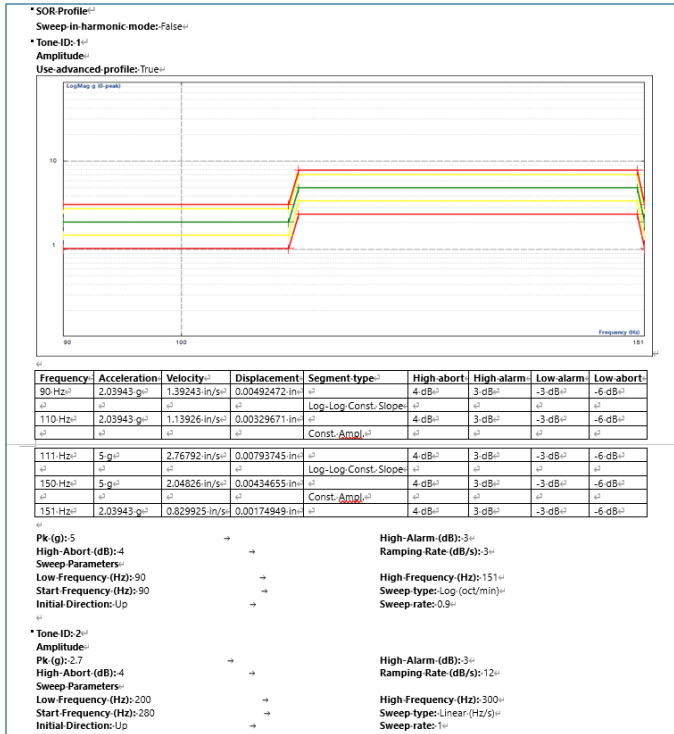

Improvements in Transducer Calibration

Measurement uncertainty at each frequency point

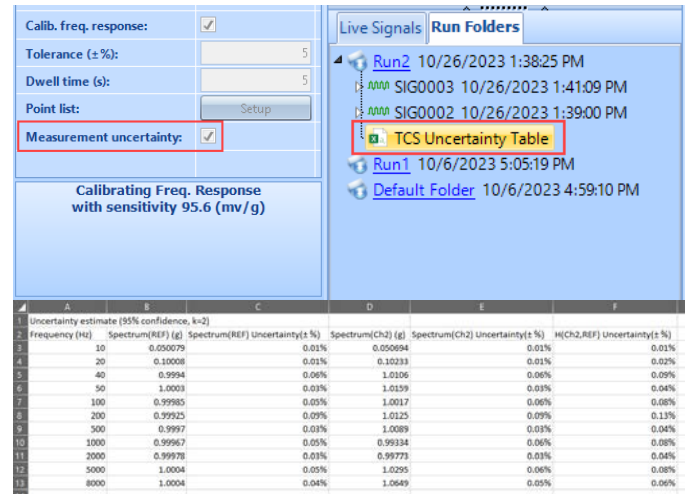

Improved Calibration Report

Transducer ID: _____

Manufacturer:

Model number:

Serial number:

ID number:

Description:

Transducer specifications

Amp. range:

Resolution:

Resonant frequency:

Temperature range:

Axis:

Test environment

Lab temperature:

Lab humidity:

Note:

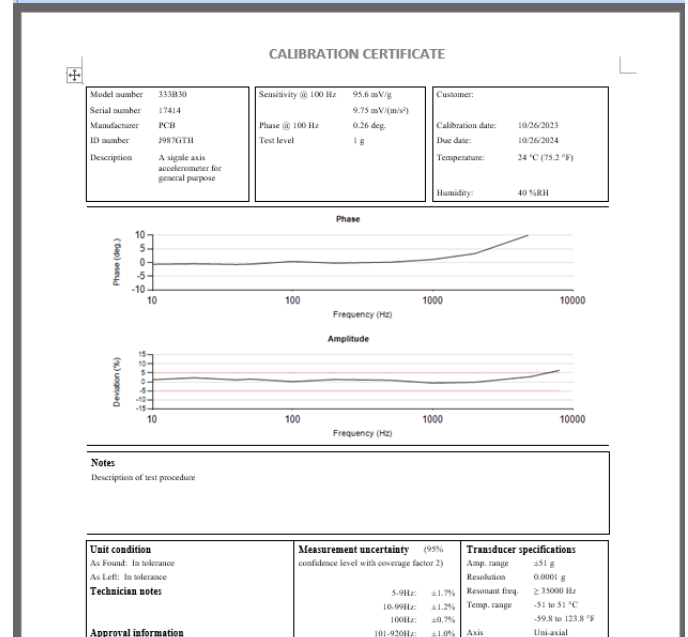

CALIBRATION CERTIFICATE

Data table		
Frequency (Hz)	Deviation (%)	Phase (deg.)
10	1.222	-0.633
20	2.251	-0.459
40	1.119	-0.703
50	1.558	-0.580
100	0.164	0.381
200	1.321	-0.201
500	0.915	0.131
1000	-0.622	1.121
2000	-0.208	3.281
3000	2.891	10.339
8000	6.444	14.206

Display velocity and displacement at each measurement point and compare to shaker limits

Frequency Hz	Acceleration g	Velocity m/s	Displacement mm (pk-pk)
1	10	0.1561	9.936
2	15	0.1041	4.416
3	40	0.07804	1.242
4	50	0.06243	0.7949
5	100	0.03122	0.1987
6	200	0.01561	0.04968
7	500	0.006243	0.007949
8	1000	0.003122	0.001987
9	2000	0.001561	0.0004968
10	5000	0.0006243	7.949E-05
11	8000	0.0003902	3.105E-05

Supports Velocity Sensor Calibration with reference acceleration sensor

Actions	On/Off	Channel type	Location ID	Measurement quantity	Engineering unit	Sensitivity	Input mode	Sensor
1	On	Control	REF	Acceleration	m/s ²	101 (mV/g)	IEPE	N/A
2	Off	Monitor	Ch2	Velocity	m/s	157.41 (mV/(m/s))	IEPE	N/A

Flexible use of any two channels for the reference sensor and the sensor under test

Actions	On/Off	Channel type	Location ID	Measurement quantity	Engineering unit	Sensitivity	Input mode	Sensor
1	On	Control	REF	Acceleration	m/s ²	101 (mV/g)	IEPE	N/A
2	Off	Monitor	Ch2	Acceleration	m/s ²	95.6 (mV/g)	IEPE	N/A
3	Off	Monitor	Ch3	Acceleration	m/s ²	100 (mV/g)	AC-Single End	N/A
4	Off	Monitor	Ch4	Acceleration	m/s ²	100 (mV/g)	AC-Single End	N/A
5	On	Monitor	Ch5	Acceleration	m/s ²	100 (mV/g)	AC-Single End	N/A
6	Off	Monitor	Ch6	Acceleration	m/s ²	100 (mV/g)	AC-Single End	N/A
7	Off	Monitor	Ch7	Acceleration	m/s ²	100 (mV/g)	AC-Single End	N/A
8	Off	Monitor	Ch8	Acceleration	m/s ²	100 (mV/g)	AC-Single End	N/A

Sweep from one measurement point to the next. Avoid ramping down and up.

EDM THV Control Software

Temperature Channels can be assigned to RTD100 and Thermocouple sensors respectively.

In the channel table, temperature channels can be assigned to RTD100 and Thermocouple sensors respectively.

On/Off	Channel type	Location ID	Module Ch#	Measurement quantity	Engineering unit	Sensitivity	Input mode	Sensor	Max. range
On	Control	Ch1	(M) 2581120	Acceleration	m/s ²	10.19716 (mV/(m/s ²))	AC-Single End	N/A	20.000
On	Monitor	Ch2	(M) 2581120	Acceleration	m/s ²	10.19716 (mV/(m/s ²))	AC-Single End	N/A	20.000
Off	Monitor	Ch3	(M) 2581120	Acceleration	m/s ²	10.19716 (mV/(m/s ²))	AC-Single End	N/A	20.000
Off	Monitor	Ch4	(M) 2581120	Acceleration	m/s ²	10.19716 (mV/(m/s ²))	AC-Single End	N/A	20.000
Off	Monitor	Ch5	(M) 2581120	Acceleration	m/s ²	10.19716 (mV/(m/s ²))	AC-Single End	N/A	20.000
Off	Monitor	Ch6	(M) 2581120	Acceleration	m/s ²	10.19716 (mV/(m/s ²))	AC-Single End	N/A	20.000
Off	Monitor	Ch7	(M) 2581120	Acceleration	m/s ²	10.19716 (mV/(m/s ²))	AC-Single End	N/A	20.000
Off	Monitor	Ch8	(M) 2581120	Acceleration	m/s ²	10.19716 (mV/(m/s ²))	AC-Single End	N/A	20.000
On	Control	Tp1	(M) 20181408	Temperature	°C	N/A	RTD PT100	N/A	N/A
On	Monitor	Tp2	(M) 20181408	Temperature	°C	N/A	RTD PT100	N/A	N/A
On	Monitor	Tp3	(M) 20181408	Temperature	°C	N/A	Thermocouple K	N/A	N/A
Off	Monitor	Tp4	(M) 20181408	Temperature	°C	N/A	N/A	N/A	N/A
Off	Monitor	Tp5	(M) 20181408	Temperature	°C	N/A	RTD PT100	N/A	N/A
Off	Monitor	Tp6	(M) 20181408	Temperature	°C	N/A	RTD PT100	N/A	N/A
Off	Monitor	Tp7	(M) 20181408	Temperature	°C	N/A	RTD PT100	N/A	N/A
Off	Monitor	Tp8	(M) 20181408	Temperature	°C	N/A	RTD PT100	N/A	N/A
Off	Monitor	Tp9	(M) 20181408	Temperature	°C	N/A	RTD PT100	N/A	N/A
Off	Monitor	Tp10	(M) 20181408	Temperature	°C	N/A	RTD PT100	N/A	N/A

16 Additional Temperature Monitoring Channels

16 additional temperature monitoring channels with the new chamber controller.

Signal name	Units	Signal unit	Site definition
PLC_TEMP1	°C	°C	PLC
PLC_TEMP2	°C	°C	PLC
PLC_TEMP3	°C	°C	PLC
PLC_TEMP4	°C	°C	PLC
PLC_TEMP5	°C	°C	PLC
PLC_TEMP6	°C	°C	PLC
PLC_TEMP7	°C	°C	PLC
PLC_TEMP8	°C	°C	PLC
PLC_TEMP9	°C	°C	PLC
PLC_TEMP10	°C	°C	PLC
PLC_TEMP11	°C	°C	PLC
PLC_TEMP12	°C	°C	PLC
PLC_TEMP13	°C	°C	PLC
PLC_TEMP14	°C	°C	PLC
PLC_TEMP15	°C	°C	PLC
PLC_TEMP16	°C	°C	PLC

EDM THV and EDC support Spider-101 v3

EDM THV and EDC have been updated to support Spider-101 v3 as a temperature/humidity controller and a temperature/humidity/vibration controller.

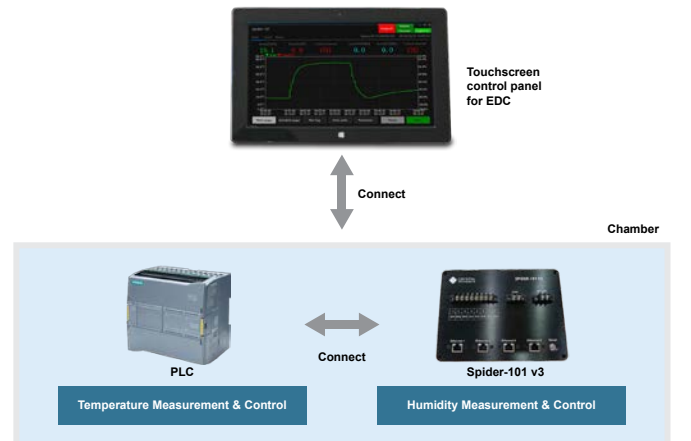

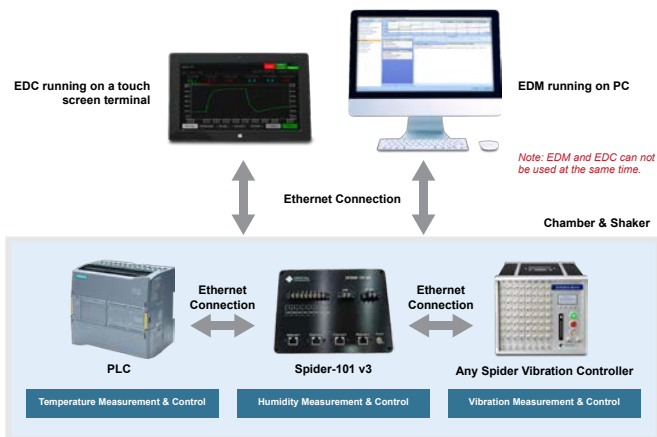
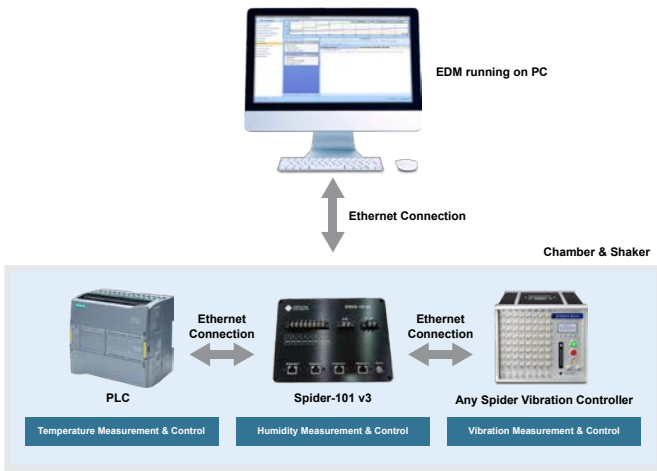
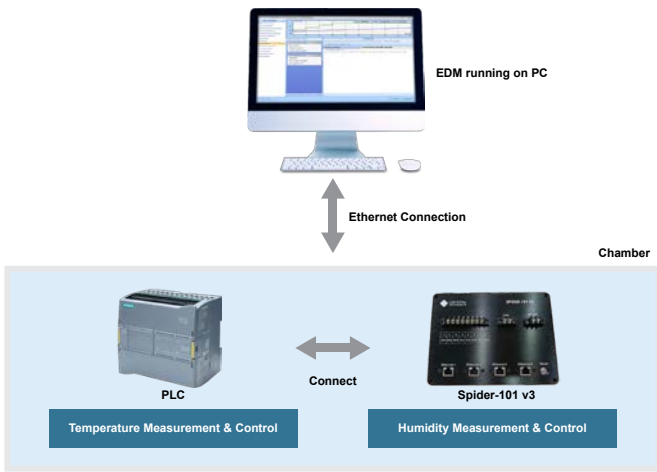

Air Dryer Support

Accelerates humidity control by actively managing the installed air dryer.

Note: Hardware support for the air dryer is essential to utilize this advanced software feature.

Product Temperature Control

Empowers the control algorithm to manage both chamber and product temperatures when a dedicated temperature sensor is installed on the product under test.

Liquid Nitrogen Cooling Support (optional)

The controller can efficiently manage a liquid nitrogen device

installed in the chamber to facilitate cooling. Execution of this software feature requires specific hardware.

Read Chamber Status with Modbus

The chamber controller is equipped with a Modbus interface to facilitate communication with external devices.

Other Improvements in EDM THV

- Report Builder implemented in EDM THV. The report builder feature is already available in EDM VCS.
- “Add existing run folders” feature implemented in EDM THV. It is already available in EDM VCS.
- An LK for Spider-101 v3 enables EDM THV and EDC software features to work with any Spider-101 v3 hardware, regardless of the serial number.
- Version control implemented for control logic files and customize EDM THV display based on different versions.

Experimental Modal Analysis

Enhancement of geometric modelling

The default libraries for quick creation of sub-structure models have been enhanced to assist users in extruding, revolving and creating intricate 3D geometries.

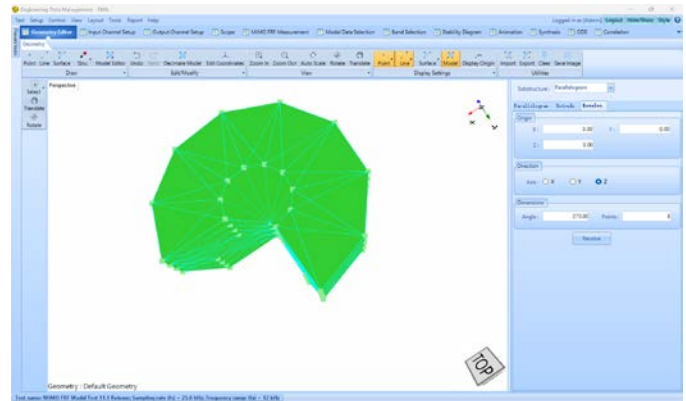

Front-end Calibration Tool (FECT)

Improved Message for Spider-80M Factory Calibration

The labels ‘H’ and ‘L’ on the switch of the Spider-80M FECT fixture indicate the connection to Output 1-4 or Output 5-8, respectively. Displaying ‘H’ or ‘L’ in the message helps clarify the switch position.

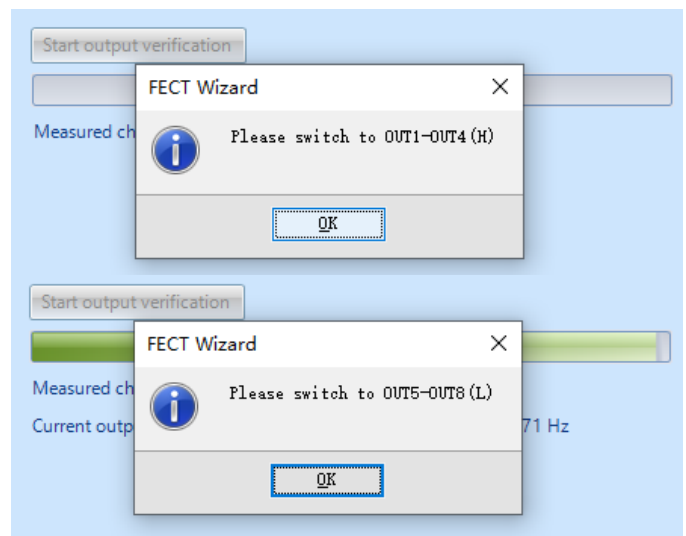

Apply calibration results to passing channels and skip those that failed

Allow calibration to proceed even if a channel failed. Calibration results can be applied to passing channels only and skip those that failed.

Front-End Calibration Tool Pro

Apply the adjustment to the instrument

Channel 4 calibration failed. You may skip Apply Adjustment and calibrate again. Or apply adjustments to other channels and channel 4 remains unchanged.

Apply Adjustment

Front-End Calibration Tool Pro

End of verification

Verification failed. please calibrate again or exit without calibration. Channel 4 verification failed. Save the verification report or exit without saving.

Save Verification

Press Finish to exit and restart the Front-End.

Factory Calibration Supports Keithley DMM6500

In addition to Fluke 8845A, Keithley DMM 6500 can now be used in Factory calibration (automatic and detailed calibration process and comprehensive calibration report).



Factory Calibration Supports Spider-80M FECT Fixture

Factory Calibration now supports an automatic calibration process on the Spider-80M with a designated multimeter and the Spider-80M FECT Fixture.



Include 1 V Range Measurements for Spider-80SG/80SGi/80Gi

New Spider-80SG/80SGi/80Gi hardware has 1 V measurement range. FECT supports calibration of the new hardware and verification in the range.

Verified Gain and Offset Errors before Adjustment (As Found Data)

Channel ID	Calibration Range	Reference Offset	Measured Offset	Gain Error	Results	Offset Tolerance	Gain Error Tolerance
Output 1	10 V	0 V	0.00748 V	0.05 %	Pass	± 0.15000 V	5.00 %
Output 1	0.1 V	0 V	0.00001 V	0.27 %	Pass	± 0.15000 V	5.00 %
Input 1	10 V	0 V	-0.00461 V	0.35 %	Pass	± 0.15000 V	5.00 %
Input 2	10 V	0 V	-0.00161 V	0.35 %	Pass	± 0.15000 V	5.00 %
Input 3	10 V	0 V	-0.00236 V	0.35 %	Pass	± 0.15000 V	5.00 %
Input 4	10 V	0 V	-0.00312 V	0.35 %	Pass	± 0.15000 V	5.00 %
Input 5	10 V	0 V	-0.00395 V	0.34 %	Pass	± 0.15000 V	5.00 %
Input 6	10 V	0 V	-0.00256 V	0.35 %	Pass	± 0.15000 V	5.00 %
Input 7	10 V	0 V	0.00114 V	0.35 %	Pass	± 0.15000 V	5.00 %
Input 8	10 V	0 V	0.00670 V	0.35 %	Pass	± 0.15000 V	5.00 %
Input 1	1 V	0 V	-0.00049 V	0.34 %	Pass	± 0.15000 V	5.00 %
Input 2	1 V	0 V	0.00006 V	0.34 %	Pass	± 0.15000 V	5.00 %
Input 3	1 V	0 V	-0.00004 V	0.33 %	Pass	± 0.15000 V	5.00 %
Input 4	1 V	0 V	-0.00005 V	0.34 %	Pass	± 0.15000 V	5.00 %
Input 5	1 V	0 V	0.00000 V	0.33 %	Pass	± 0.15000 V	5.00 %
Input 6	1 V	0 V	-0.00032 V	0.33 %	Pass	± 0.15000 V	5.00 %
Input 7	1 V	0 V	-0.00010 V	0.34 %	Pass	± 0.15000 V	5.00 %
Input 8	1 V	0 V	-0.00011 V	0.33 %	Pass	± 0.15000 V	5.00 %

Signal Viewer Improvements

Signal Viewer report generation should have file name and directory

When generating a report in Signal Viewer, in contrast to VCS, the Generate Report menu will appear. This allows the user to select some information about the report that will be generated. Use this menu to enter a custom name or file path to export, otherwise use the defaults.

Generate Report

Options

Template: My Report

Default directory: C:\Users\MCarroll\Do [Browse]

Report name: 11_12_17_717.pdf

Signal to report (.atx / .dat):

- Select saved signal: SIG0001.atx, SIG0005.atx, SIG0003.atx, SIG0002.atx
- Select run log file: 2-2-2023 2-33-22 PM.onlog

Run log to report (-origlog):

- Select run log file: 2-2-2023 2-33-22 PM.onlog

Report builder preview

Title section (SIG0001, SIG0005, SIG0003, SIG0002)

User notes (SIG0001, SIG0005, SIG0003, SIG0002)

Testing results (SIG0001, SIG0005, SIG0003, SIG0002)

Composite display

Channel status

Active windows

Active tab

Run information (2-2-2023 2-33-22 PM)

Run log

Test configuration (SIG0001, SIG0005, SIG0003, SIG0002)

Test parameters

Input channels

Profile

Run schedule

Shaker limits

Limit channels

Generate report menu should not open if no signal files are loaded

Signal Viewer is designed to always associate reporting with one or more signal files. The program will check to see if any loaded signals can be reported before the user opens the Generate Report menu to select a signal to report and to specify various details. If none exists, it will not let the user proceed.

Report Options

Custom templates Report settings

Templates: My Report [Create] [Rename] [Delete] [Import] [Export] [Reset defaults]

Report builder [Logs] [Page] [Graphs]

Search report items

Title section

User notes

Testing results

Composite display

Channel status

Active windows

Active signal window

Active tab

All signal window

Run information

Run log

Test configuration

Test parameters

Input channels

Profile

Run schedule

Shaker limits

Limit channels

Shaker specs

Spider system setting

Spider system config

Channel calibration

No available signal files to report - folders must be open to report signals inside.

Generate report

Default signal to report should be any plotted signals

Based on user feedback, the active signals are selected by default when a new report is generated. The user can still select different signals from the menu if necessary:

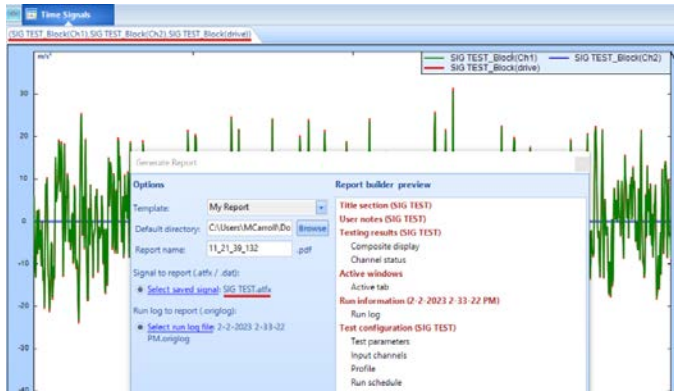

Use the following sequence of actions to check for a default signal:

- Check the current active window.
- If none, check the current active tab.
- If none, check for the first signal in the tree.
- If none at the end, do not let the user generate a report.

Signal Viewer should preload all opened signals for improved filtering performance

Due to the accommodation made long ago for the Data Files panel, recording nodes would normally have to be expanded before the internal categories and signals would be loaded. However, the filtering function in Signal Viewer is always applied if active. If this filter is supposed to remove a certain type of signal, and all signals inside a recording are filtered out, the recording will be grayed out and disabled. This is not possible if the signal files are not loaded immediately, so this change was made to the Signal Viewer's import process.

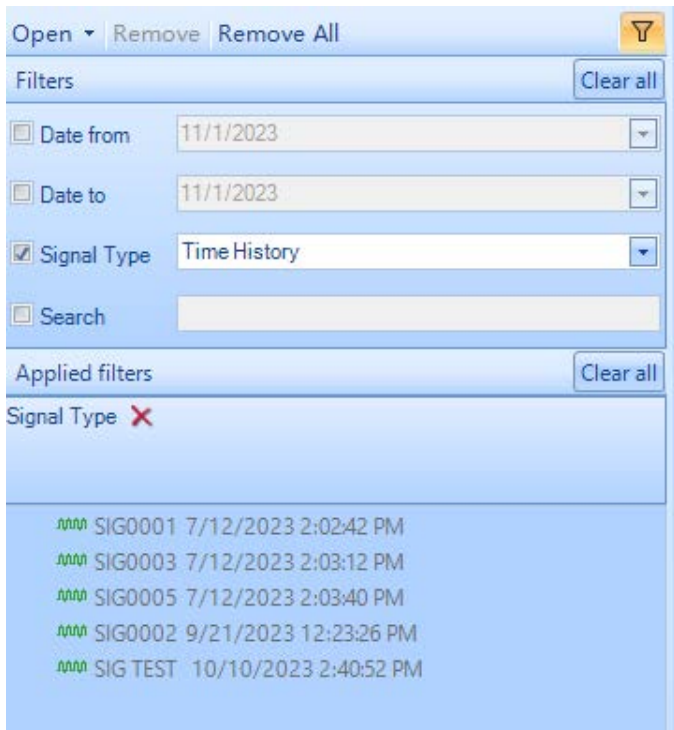

Change text to add .origlog and .atfx extensions in Report Generation window

The window that appears after clicking Generate Report in the report templates menu will display the recommended file types for the signals and run folders:

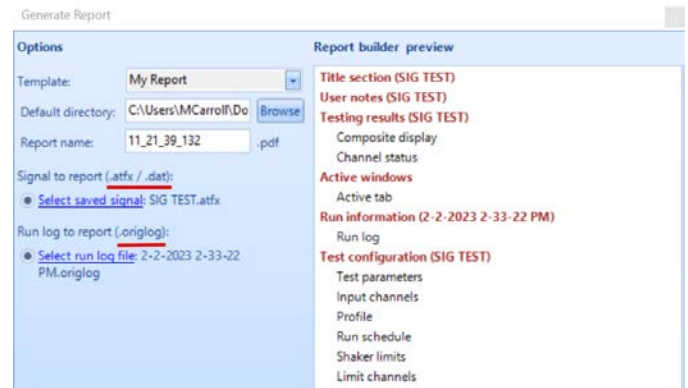

Added a "Remove all" button next to "Remove"

Previously, a Remove button was provided to remove one signal or folder at a time in the Data Files panel. Now, a "Remove all" button is added for convenience:

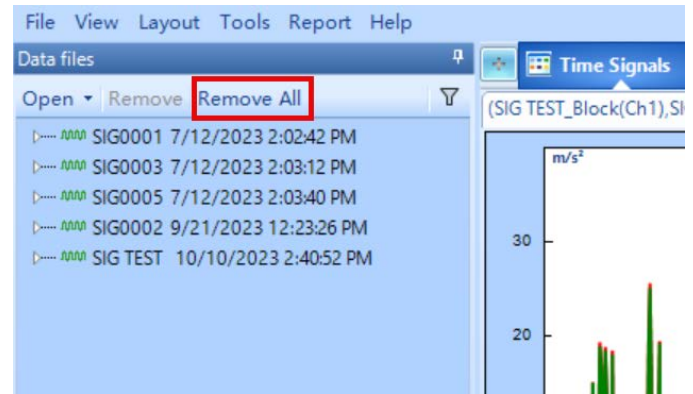

General Improvements

EDM Software supports In-line Charge Converter and External Charge Amplifier on all Spider products

Actions	On/Off	Location ID	Measurement quantity	Engineering unit	Sensor	Max. sensor range	Sensitivity	Channel type	Input mode
1	On	Ch1	Acceleration		N/A	20 (V)	101 (mV/g)	Monitor	IEPE
2	On	Ch2	Acceleration		N/A	20 (V)	99.442 (mV/g)	Monitor	IEPE
3	On	Ch3	Acceleration		N/A	20 (V)	9.69 (mV/g)	Monitor	IEPE
4	On	Ch4	Acceleration		N/A	20 (V)	10.701 (mV/g)	Monitor	AC-Single End DC-Single End
5	On	Ch5	Acceleration		N/A	20 (V)	100 (mV/g)	Monitor	AC-Differential DC-Differential
6	Off	Ch6	Acceleration		N/A	20 (V)	100 (mV/g)	Monitor	In-Line Charge Convert External Charge Amplif
7	Off	Ch7	Acceleration		N/A	20 (V)	100 (mV/g)	Monitor	External Charge Amplif

Rename Test

Improved convenience method to rename a test, as well as its test directory for future runs

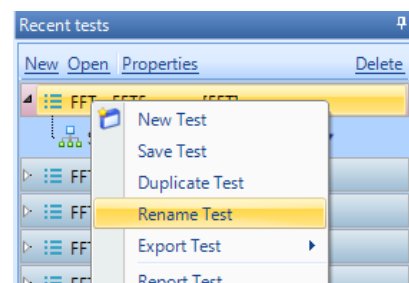

Cursor / Marker window no longer automatically shows

When plotting cursor or markers, the Cursor / Marker Window no longer automatically pops up. Instead, there is a dedicated right-click menu option to show the Cursor / Marker Window.



RMS box now supports copying to clipboard

Right-click on the RMS box display to copy the RMS values to clipboard

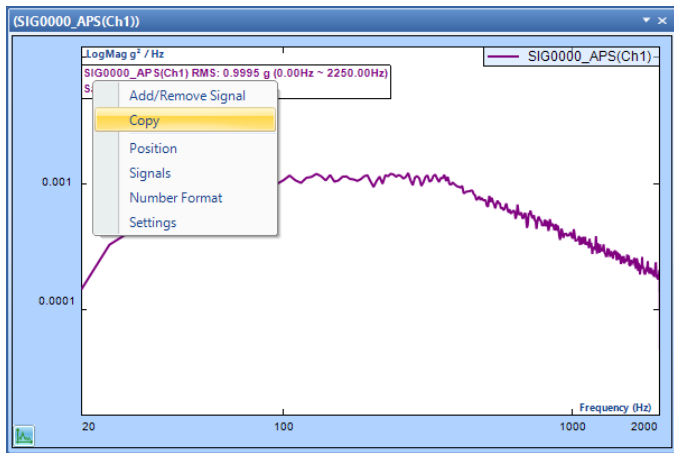

Spectrum Format (Global Settings) refactor

The previously separate **Signal export > Spectrum format** and **Default display format** pages (both in **Global Settings**) have now been consolidated to a **Spectrum Format** page directly under **Global Settings**.

The default values adhere to industry standards (different between VCS, DSA, Modal, etc.)

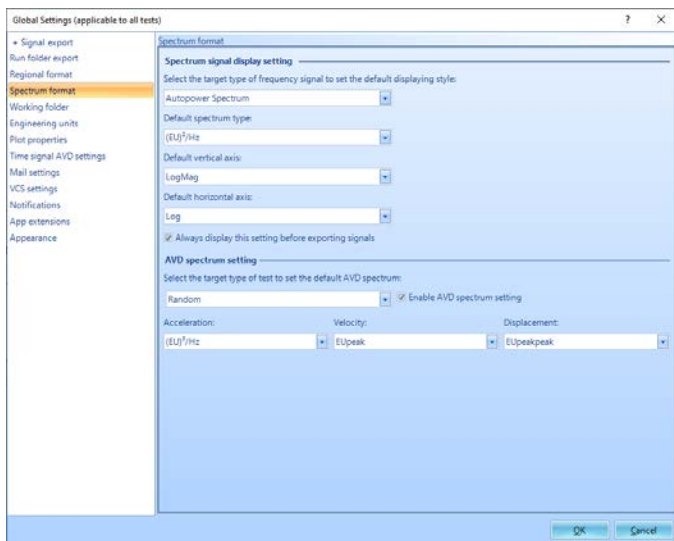

Drag file to plot signal

Files (ex: SIG007) can be dragged and dropped onto a plot. This will attempt to plot any matching signals (ex: Spectrum(Ch1)) already present on the plot. This is useful for comparing the same channel signal across different timestamps or multiple test runs.

In the example below, the signal Spectrum(Ch1) is compared between SIG007 and SIG006

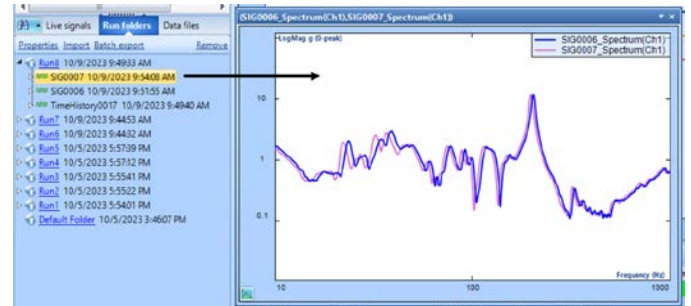

Saving Multiple Licenses

To save multiple licenses into one file, users can shift click licenses in the License Key Management page.

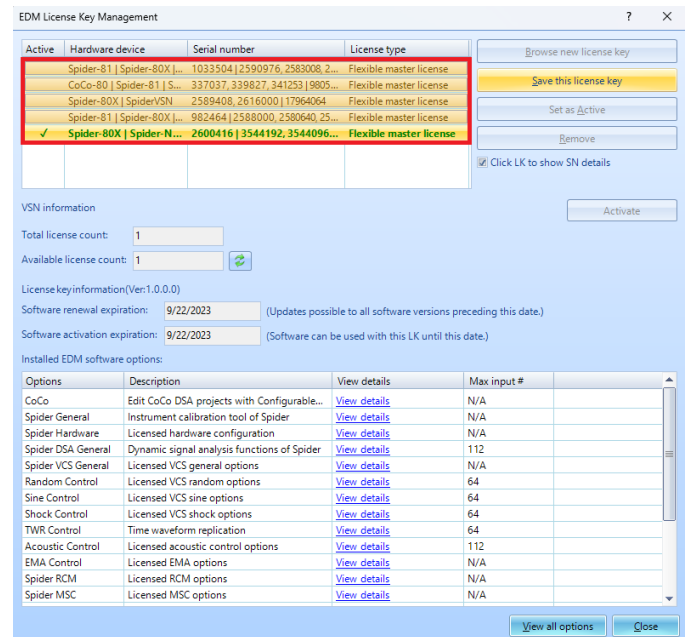

Clicking "Save this license key" will allow users to choose where to save the .licm file.

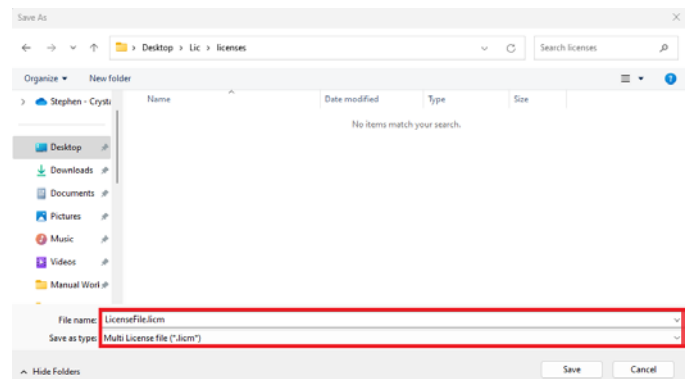

Import the .licm keys back into EDM by clicking the “Browse new license key” button.

The screenshot shows the license management interface. At the top, there is a table with columns: Active, Hardware device, Serial number, and License type. The first row is highlighted in yellow and has a checkmark in the 'Active' column. Below the table are buttons: 'Browse new license key', 'Save this license key', 'Set as Active', 'Remove', and 'Click LK to show SN details'. Below the buttons is a file explorer window showing the path 'Desktop > Lic > licenses' and a file named 'LicenseFile.licm' with a size of 45 KB.

Active	Hardware device	Serial number	License type
	Spider-81 Spider-80X ...	1033504 2590976, 2583008, 2...	Flexible master license
	CoCo-80 Spider-81 S...	337037, 339827, 341253 9805...	Flexible master license
	Spider-80X SpiderVSN	2589408, 2616000 17964064	Flexible master license
✓	Spider-80X Spider-N...	2600416 3544192, 3544096...	Flexible master license

Active Key Column

The active column indicates which license key is currently active.

Active	Hardware device	Serial number	License type
	Spider-81 Spider-80X ...	1033504 2590976, 2583008, 2...	Flexible master license
	CoCo-80 Spider-81 S...	337037, 339827, 341253 9805...	Flexible master license
	Spider-80X SpiderVSN	2589408, 2616000 17964064	Flexible master license
✓	Spider-80X Spider-N...	2600416 3544192, 3544096...	Flexible master license

Improvements to Spider-80T/Ti temperature calibration interface

The screenshot shows the 'Temperature Calibration Wizard' window. The title bar says 'Temperature Calibration Wizard'. The main content area has a blue background and a flame icon. The text reads 'Validate Channel 1'. Below this, there are three numbered steps: 1. Input 4.096 mV (100 °C) using the thermocouple calibrator. 2. Click "Measure" when ready ... 3. Click "Next" if the calibration passed. Otherwise repeat calibration or skip channel. In the center, the value '4.087mV' is displayed in large red font. To the right of this value are 'Measure' and 'Skip' buttons. At the bottom, there are 'Export report', '< Back', 'Next >', and 'Cancel' buttons.

SOFTWARE RELEASE HISTORY

Type	Release	Exact Version	Release Date
Release	EDM 4.2	CI 4.2.0.3	02/28/2014
Patch	EDM 4.2.0	CI 4.2.0.14	07/02/2014
Release	EDM 5.0	CI 5.0.0.2	11/27/2014
Patch	EDM 5.0.1	CI 5.0.1.3	02/27/2015
Release	EDM 5.1	CI 5.1.0.6	08/12/2015
Release	EDM 6.0	CI 6.0.0.1	05/19/2016
Patch	EDM 6.0.2	CI 6.0.2.9	08/09/2016
Release	EDM 6.1	CI 6.1.0.4	02/07/2017
Patch	EDM 6.1	CI 6.1.0.27	08/22/2017
Release	EDM 7.0	CI 7.0.0.6	02/01/2018
Patch	EDM 7.1	CI 7.1.0.7	07/19/2018
Release	EDM 8.0	CI 8.0.0.1	02/02/2019
Release	EDM 8.1	CI 8.1.0.1	11/13/2019
Release	EDM 9.0	CI 9.0.0.4	06/05/2020
Release	EDM 9.1	CI 9.1.0.0	02/03/2021
Release	EDM 10.0	CI 10.0.0.2	10/26/2021
Release	EDM 10.1	CI 10.1.0.1	09/09/2022
Release	EDM 11.0	CI 11.0.0.1	01/19/2023
Release	EDM 11.1	CI 11.1.0.0	11/23/2023

VERSION COMPATIBILITY

Product and Software Version	Firmware Versions
Spider-80X/80Xi/80Hi/80Ci	
EDM Testing 11.0.0.x	11.1.0.x
Spider-81 (v7.x)	
EDM Testing 11.0.0.x	11.1.0.x
Spider-81B (v7.x)	
EDM Testing 11.0.0.x	11.1.0.x
Spider-80SG/SGi	
EDM Testing 11.0.0.x	11.1.0.x
Spider-20HE/20i	
EDM Testing 11.0.0.x	11.1.0.x

Product and Software Version	Firmware Versions
CoCo-80X/90X	
EDM Testing 11.0.0.x (EDM CoCo for DSA)	2.0.x or above
CoCo-70X	
EDM Testing 11.0.0.x (EDM CoCo for DSA)	2.0.x or above

SYSTEM REQUIREMENTS

Minimum system requirements:

- **Operating system support:** Windows 7 SP1 or higher
- **Operating system type:** 32-bit or 64-bit
- **Processor speed:** 1.5 GHz Dual-Core x86
- **RAM:** 4 GB
- **Available storage space:** 10 GB

Recommended system requirements (minimum for Spider systems higher than 16 channels):

- **Ethernet speed:** at least 1 Gbps Ethernet port on the computer
- **Network cables:** provided by Crystal Instruments
- **Operating system:** Windows 10, 64-bit
- **Processor:** Intel Core i7, 2.0 GHz or higher
- **RAM:** 8 GB DDR3 1600 or higher
- **Available storage space:** 10 GB or higher
- **Spider-HUB firmware version:** 2.0.5.17 or higher

Crystal Instruments Corporation
2090 Duane Avenue
Santa Clara, CA 95054

Phone: +1 (408) 986-8880
Fax: +1 (408) 834-7818

www.crystalinstruments.com
info@go-ci.com

Crystal Instruments Testing Lab
15661 Producer Lane, STE H
Huntington Beach, CA 92649

Crystal Instruments Testing Lab
1548A Roger Dale Carter Boulevard
Kannapolis, NC 28081

© 2023 Crystal Instruments Corporation. All Rights Reserved. 12/2023

Notice: This document is for informational purposes only and does not set forth any warranty, expressed or implied, concerning any equipment, equipment feature, or service offered or to be offered by Crystal Instruments. Crystal Instruments reserves the right to make changes to this document at any time, without notice, and assumes no responsibility for its use. This informational document describes features that may not be currently available. Contact a Crystal Instruments sales representative for information on features and product availability.